

CITY MULTI[®]
VRFZ TECHNOLOGY

Building Comfort Solutions

Variable Refrigerant
Flow Zoning Systems



www.mehvac.com



HVAC Advanced Products Division

Mitsubishi Electric is a world leader in all types of *quality* products. Our consumer products, like high-definition televisions and home theater systems, have won awards for innovation and *quality*.

Semi-conductors, opto-electronics devices, communication products, power generation systems, and, of course, heating and air-conditioning systems are all a part of the global Mitsubishi Electric family.

Quality describes the products engineered and manufactured by Mitsubishi Electric. *Quality* is what comes to mind when we think of Mitsubishi televisions, elevators, and air-handling systems – *quality* that comes from the fact that the majority of components found in Mitsubishi Electric products are made

by Mitsubishi Electric factories. *Quality* comes from a company that controls its own research, development, design, materials and manufacturing. From beginning to end, it is all Mitsubishi Electric engineering; it is all about *quality*.

The technological advances developed by Mitsubishi Electric are apparent as innovative features throughout all of Mitsubishi Electric's products. Efficient and technologically advanced motors, controls, INVERTER-driven compressors and micro-processors are all developed by Mitsubishi Electric and used in the CITY MULTI® Variable Refrigerant Flow Zoning (VRFZ) systems. Cross-functional engineering allows Mitsubishi Electric to provide innovative, new products in the United States that have a proven track record worldwide.



Good for the environment and your bottom line.

Mitsubishi Electric HVAC Advanced Products Division promotes environmental awareness through not only the innovative technology that encompass all of the products, but in how the products themselves are designed and manufactured. Some examples of this awareness are:

- **Eco-friendly refrigerant:** Environmentally-friendly R410A refrigerant offers zero Ozone Depletion Potential (ODP) and allows for higher heat transfer coefficient (COP). This innovative feature means a reduction in equipment size, a reduction in piping size and higher pressure for greater performance. Smaller equipment also means less impact on the environment at the end of the product's life cycle.
- **Standard compliance:** All Mitsubishi Electric HVAC products follow standards and guidelines as set forth by the Energy Star, EPA, ARI, ASHRAE, UL, ETL and ISO.
- **Recycling design:** Our air conditioners are specially designed to allow for easy cleaning, efficient disassembly and more practical recycling. The number of parts used in indoor units has been reduced by adopting modular components, a process which also simplifies materials separation for recycling. To date, as much as 89.8 percent of the materials used to build a standard CITY MULTI system component are recyclable.
- **Minimal impact on landfills:** All air-conditioning products use long-life washable filters rather than disposable filters.
- **Smart energy usage:** Mitsubishi Electric INVERTER zoning systems smartly deliver only the amount of capacity needed unlike a typical full-power ON system. Individual indoor air handlers are installed within the zone. These air handlers measure the load for that specific zone and deliver for added efficiency only the capacity needed directly to the space, as compared to energy lost in long duct runs. If the zone is not being used, you do not have to continually condition the space. Smarter sensing technology and microprocessors enhance the system's ability to measure room temperature accurately for added comfort, performance and efficiency.

Table of Contents

Introduction	2
Overview of CITY MULTI®	4
System Components	6

Outdoor Units

Technology Overview	8
R2-Series Overview	10
R2-Series Specifications	12
BC Controller Specifications	14
Y-Series Overview	16
Y-Series Specifications	17
H2i™ Y-Series Overview	20
H2i Y-Series Specifications	21
S-Series Overview	22
S-Series Specifications	23

OUTDOOR UNITS

Water-Source Units

W-Series Overview	24
W-Series Specifications	26

WATER-SOURCE

Indoor Units

Indoor Unit Overview	28
PKFY Wall-mounted	30
PLFY Cassette (4-way)	32
PMFY Cassette (1-way)	36
PCFY Ceiling-suspended	38
PDFY/PEFY Ceiling-concealed Ducted	40
PFFY Floor-standing	44
PV FY Vertical Air Handler	46

INDOOR UNITS

Controls

Controls Network Overview	48
Controls Network Specifications	49
AG-150 Centralized Controller	50
GB-50A Centralized Controller	51
GB-24 Centralized Controller	52
Controllers	54
I/O Control Boards	56
TG-2000™ Integrated System Software	57
System Integration: LonWorks® and BACnet®	58

CONTROLS

Lossnay® Energy Recovery Ventilators (ERVs)	59
---	----

ERV

Maintenance Tool Software Overview	60
Design Tool Software Overview	62

TOOLS

CITY MULTI® VRFZ

(Variable Refrigerant Flow Zoning) Systems:
a user-friendly, ductless, or ducted
commercial or residential comfort
control system.

Quality and reliability from a name you know: Mitsubishi Electric

CITY MULTI is the first two-pipe, simultaneous cooling and heating system available in the United States and around the world. Our technology has a long and proven track record of quality and reliability around the world. Mitsubishi Electric, an acknowledged global industry leader, has installed CITY MULTI zoning systems in buildings throughout Asia, Europe, and other countries throughout the world for nearly twenty years with great success and customer satisfaction. Let a Mitsubishi Electric representative show you how you can put the ultimate cooling and heating system to work for you and your customers right here, right now. Contact us at 800-433-4822 (option #4).

CITY MULTI advantage

The best way to ensure total comfort for the occupants of offices, schools, hospitals, assisted-living facilities, hotels and more is to provide each individual zone with a personalized comfort system. Zoning offers maximum individual comfort and energy savings because only the zones that need air conditioning receive it. Each zone of the CITY MULTI system has its own indoor unit or group of indoor units that precisely control the indoor temperature, while operating with minimum energy usage. You set the comfort level, then relax.

The CITY MULTI VRFZ (Variable Refrigerant Flow Zoning) system takes advantage of INVERTER technology by varying the speed of the compressor in the outdoor unit to meet the changing load requirements in each of the indoor zones. An energy-wasting “dump zone” for excess hot or cold air, as used with a typical air-conditioning, system is not necessary with CITY MULTI systems. Our system recovers the energy in other zones to provide comfort only to the zones calling for air conditioning.

Complete zoning system

A CITY MULTI VRFZ system consists of an outdoor unit, a branch circuit (BC) Controller (depending on series), multiple indoor units, and corresponding system and zone controllers.

Installing this fully integrated zoning system is fairly simple. A single outdoor modular unit or combined modular units, the BC Controller, and each of the indoor units are connected by a

CITY MULTI®
VRFZ TECHNOLOGY

two-pipe refrigerant system. The outdoor unit and the BC Controller, depending on the series, work in unison to deliver the required refrigerant flow to each indoor unit. The Direct Digital Controls (DDC) system controls the network link between the indoor units with the BC Controller and the outdoor unit to provide convenient control of the entire system. Separate remote controllers connected to individual indoor units — or groups of indoor units — provide individual zone control.

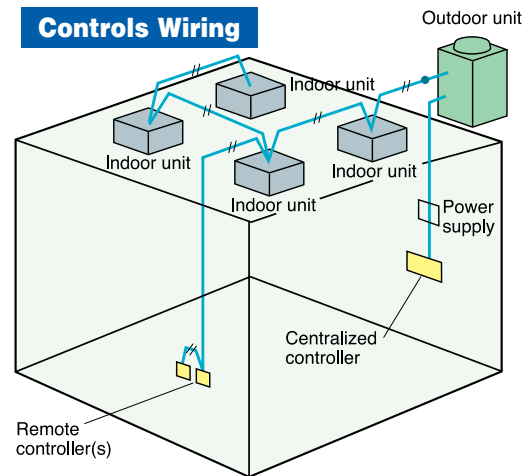

These controllers provide a wide variety of configuration settings to satisfy each zone's requirements, including temperature control and timer settings.

Design flexibility

CITY MULTI VRFZ systems provide engineers the flexibility to meet their application designs, ranging from the simple to the complex. CITY MULTI R2 and Y-Series systems, available in 208/230V and 460V capabilities, can be designed for up to 50 zones per system. The W-Series system can work with up to sixteen zones and the S-Series system can be configured for up to eight zones. Systems with Hyper-Heating INVERTER (H2i™) have the capability to connect with up to 24 indoor units. Multiple CITY MULTI systems can be integrated into our controls network to air condition and manage up to 2,000 zones from a single-networked PC using Mitsubishi Electric furnished software.

Mitsubishi's INVERTER advantage

INVERTER

CITY MULTI's INVERTER technology is highly responsive and efficient. By varying the capacity of the system to match your indoor space load requirements, while responding to outdoor conditions, CITY MULTI provides the ultimate in precise indoor comfort control plus great energy savings with the use of a single INVERTER compressor for each outdoor unit or outdoor modular unit.

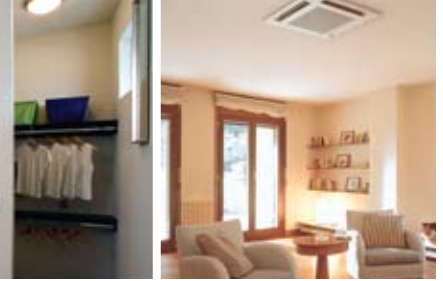

Ductless or ducted indoor units for ultimate flexibility

A CITY MULTI outdoor unit can operate up to 50 ductless or ducted indoor units, depending on the outdoor unit, making the system ideal for virtually any type of application or any variety of applications within the same building. Do you need air conditioning on demand in a conference room? CITY MULTI provides that. Do you need a centralized system to cool or heat a large working area all day? CITY MULTI does that. Do you want precise temperature control in a confined zone with no room for ductwork? CITY MULTI accommodates this need as well.

CITY MULTI VRFZ systems provide virtually everything desired in an air-conditioning system. Direct Digital Controls (DDC) ensure optimized operation of the system. Mitsubishi Electric's INVERTER-driven technology and electronic expansion valves vary the capacity of the system to match the indoor space load requirements. This feature saves energy and provides ultimate indoor comfort. Up to 50 indoor units can be employed with capacities that connect up to 150% of the outdoor unit's rated capacity.

Advanced comfort control

The CITY MULTI Controls Network (CMCN) uses Mitsubishi Electric's advanced M-NET technology to provide individual, personalized comfort and powerful, centralized control. Each component is integrated onto the secure high-speed communication bus to provide precise temperature control by varying the output of the outdoor unit(s) to match the needs of each zone.

Easy to install, easier to operate

CITY MULTI is a simple, two-pipe system with easy, non-polar, two-wire control connections. With the modular outdoor unit's compact design, transportation can be managed through a standard, six-person elevator during the building process. These features add up to less labor and materials, quicker, easier installation, and a much lower overall operating cost for the building owner.

So quiet, you'll hardly notice it's there

CITY MULTI is designed to provide the quietest possible operation for both indoor and outdoor environments. Indoor units operate as low as 24 dB(A), and outdoor units operate as low as 58 dB(A). That's a major benefit, especially for hospitals, other healthcare facilities, schools, and libraries. CITY MULTI dependably provides comfortable cooling and heating all year long.

Sustainable

The CITY MULTI technology is designed to allow building owners and designers as many opportunities as possible to attain Leadership in Energy and Environmental Design (LEED®) points when designing and applying CITY MULTI. Mitsubishi Electric is a corporate member of U.S. Green Building Council (USGBC) and is committed to sustainable products and design. CITY MULTI VRFZ technology may contribute to a building receiving LEED points in areas of Energy and Atmosphere and Indoor Air Quality.

Heat Recovery (R2- / WR2-Series) Simultaneous cooling and heating

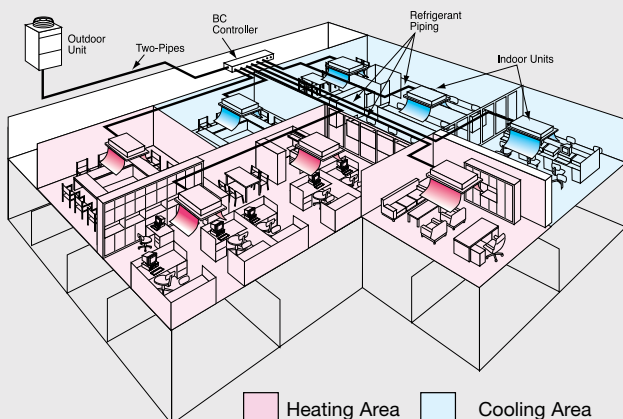

Heat Pump (Y- / WY- / S-Series)

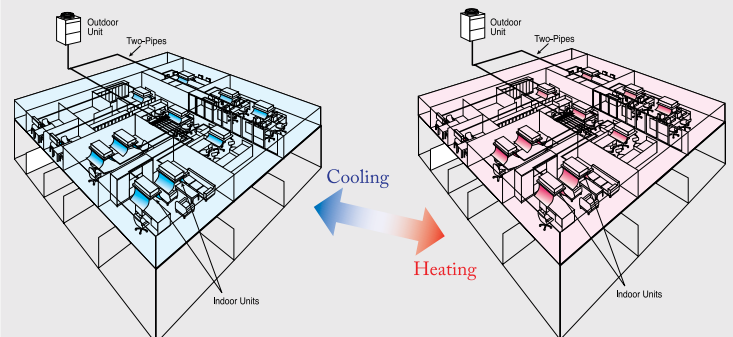

OUTDOOR UNITS

Mitsubishi Electric HVAC has an extensive outdoor unit line-up that can be tailored to any building design need. Choose from modular units that have capacities up to 30 tons for Y-Series heat pump systems, 20 tons for R2-Series heat recovery systems;

the Hyper-Heating INVERTER (H2i™) Y-Series units that provide 100% heating capacity at 5° F outdoor temperature; single-phase S-Series heat pump; W-Series water-source units available in six and eight tons.



R2-SERIES (Heat Recovery)

The R2-Series **simultaneously cools and heats** different zones within a building to provide energy-saving, heat-recovery operation through the use of the **BC Controller**, which means less work is required of the outdoor unit, and that means

energy savings and increased, overall capacity. The R2-Series can support up to 50 indoor units. New modular unit design features a compact chassis, smaller installation footprint, low operating sound, easy piping and maintenance design, and are lightweight.

R2-Series units are available in both 208/230V and 460V for varying application needs.

Y-SERIES (Heat Pump)

Y-Series outdoor units are flexible enough to cool or heat up to 50 individual zones, maximizing building design options. New modular unit design features a compact chassis, smaller installation footprint, low operating sound, easy piping and maintenance design, and are lightweight.

Y-Series units are available in both 208/230V and 460V for different applications.



S-SERIES (Powerful Single-PHASE Heat Pump)

The CITY MULTI S-Series is a **single-phase** system perfect for light commercial or large residential applications. Available in 36,000 or 48,000 Btu/h, the S-Series can provide cooling or heating for up to eight individual zones.



Hyper-Heating INVERTER (H2i™) Y-Series (Heat Pump)

Hyper-Heating INVERTER Y-Series units combine the ultimate in application flexibility, and powerful cooling and heating capabilities to deliver precise comfort control to multiple zones in a building. **Providing 100% heating capacity at 5° F outdoor temperature and 75% capacity at -13° F outdoor temperature, the H2i unit is the perfect choice for year-round comfort – even in the coldest of climates.**



WATER-SOURCE UNITS

W-SERIES WR2, WY (Heat Recovery And Heat Pump Systems)

W-Series units combine the convenience of **water-source systems with VRFZ technology**. These units are easily installed indoors, which means that system performance efficiency is independent of outdoor ambient temperatures. The W-Series includes WR2 heat recovery units for simultaneous cooling and heating, and powerful heat pump WY models.



INDOOR UNITS

Mitsubishi Electric's wide selection of different indoor unit styles allows you to choose the styles and size that meets your requirements for layout and design.



PKFY
Wall-mounted



PLFY-NBMU (4-Way)
Ceiling-recessed Cassette
(3' x 3')



PLFY-NCMU (4-Way)
Ceiling-recessed Cassette
(2' x 2')

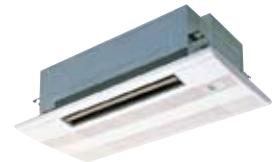

PMFY (1-Way)
Ceiling-recessed Cassette



PCFY
Ceiling-suspended

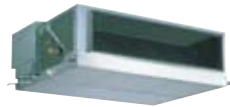

PDFY
Ceiling-concealed
Ducted Standard

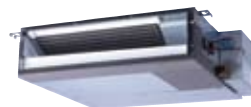

PEFY-NMSU
Ceiling-concealed
Ducted Low Profile

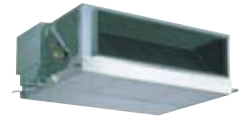

PEFY-NMHU
Ceiling-concealed
Ducted Alternate
High Static



PFFY-NEMU
Floor-standing Exposed



PFFY-NRMU
Floor-standing Concealed



PVFY
Vertical Air Handler

CONTROLS NETWORK



AG-150
Touch Screen
Centralized Controller



GB-50A / GB-24
Centralized Controller
for PC



PAC-YT34STA
Schedule Timer



PAC-YT40ANRA
On/Off Controller



PAR-21MAA
PAR-F27MEA
Remote Controllers



PAC-YT51CRB
Simple Remote



Wireless Remote



DIDO / AI
Control Boards

CITY MULTI Controls Network (CMCN) uses Mitsubishi Electric's advanced M-NET controls network

Mitsubishi Electric's reliable, high-speed communication bus, M-NET, allows data to flow in large capacities to ensure optimized system performance. Each component is integrated on the M-NET for precise temperature control by regulating the output of the outdoor unit capacity to match the comfort needs of each zone. CMCN supports integration with Building Management Systems (BMS) through LonWorks® and BACnet® interfaces.

HIGH PERFORMANCE, MODULAR CITY MULTI® VRFZ SYSTEMS

R2-Series / Y-Series / H2i™ Y-Series

CITY MULTI outdoor units feature a new modular, compact chassis, design with a smaller installation footprint, low operating sound, easy piping / maintenance, longer line lengths, and lighter weight than available on previous models. The modular unit design offers greater flexibility in increasing capacity (up to 20 tons with the R2-Series and 30 tons with the Y-Series) while adding to the number of connectable indoor units, up to 50. The modular units are available in both 208/230V and 460V for various sizes of building application requirements.



Small footprint and light weight

At 36" x 30" the R2-Series outdoor units offer one of the smallest footprints available for a six ton outdoor unit. The small size allows for the modular outdoor units to be transported to the top of buildings using a service elevator, saving the cost of using a crane. An added advantage is the vertical-air discharge design, which allows outdoor units to be installed side-by-side in a single area, saving space and resources when multiple units are involved. Plus, with the reduction of size comes the benefit of a lighter weight for each of the modular units.

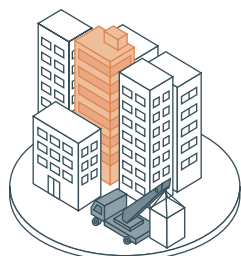
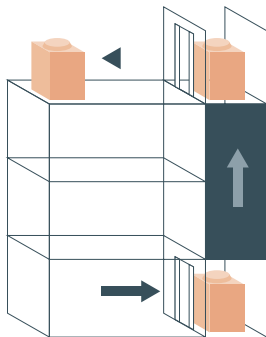

Narrow spaces between buildings makes it difficult and timely to use cranes.

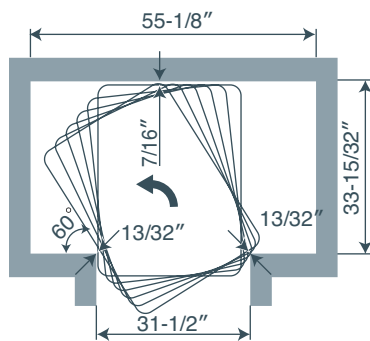

Six person elevator with CITY MULTI outdoor unit module inside for ease of transport.

Low operating sound

To reduce sound even further than previous models, the modular outdoor unit design incorporates an optional Low Sound Function. This function works by lowering the fan speed and compressor frequency proportionally with reduction in demand. The compressor compartment is sealed by metal panels to provide very low operating sound levels in all directions, as low as 58 dB(A) for a six ton unit and 65 dB(A) for a 30 ton unit.

New INVERTER-driven outdoor fan motor



High performance R410A INVERTER-driven scroll compressor

Larger projects, more options

New to the modular outdoor unit design specifications is the option for either a 208/230V, 3-Phase, 60Hz or a 460V, 3-Phase, 60Hz power source. Another feature is the larger capacities for the larger projects, up to 30 tons on select systems, an increased number of connectable indoor units up to 50 with increased line lengths. These capabilities increase the range of potential applications that CITY MULTI VRFZ systems can be specified for by an architect, engineer or building owner.

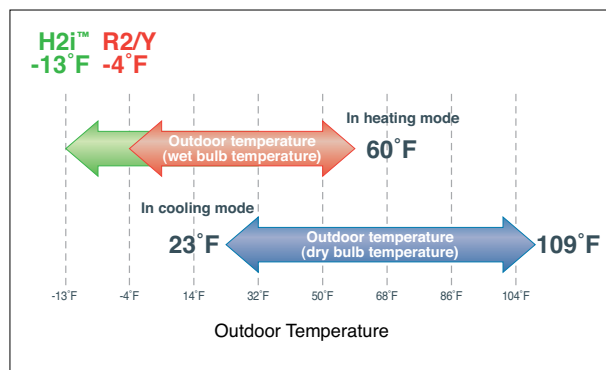

Blue Finsm treatment

The standard anti-corrosion Blue Fin treatment of the heat exchanger is especially effective in environments where traffic pollution can damage the aluminum fins, reducing the capacity and life expectancy of the unit. All CITY MULTI R410A outdoor units have been treated with Blue Fin prior to leaving the factory.



Additional protection of the frame and other component materials on all outdoors is available as an option, as indicated on the model suffix number with a '-BS'.

100% INVERTER-driven, like no other



The compressor varies its speed to match the indoor cooling or heating demand and, therefore, only consumes the energy that is required.

When an INVERTER-driven system is operating at partial load, the energy efficiency of the system is significantly higher than that of a standard fixed speed system.

Fixed speed systems can only operate at 100%, however, partial load conditions prevail for the majority of the time. Therefore fixed speed systems cannot match the annual efficiencies of INVERTER-driven systems.

Using only one INVERTER-driven compressor per outdoor unit module, the CITY MULTI outdoor units provide low starting currents (only 15 amps for a THMU-A outdoor unit), and smooth transition across the range of compressor frequencies. Minimum capacity control ranges from **six percent to 17 percent** depending on outdoor unit systems.

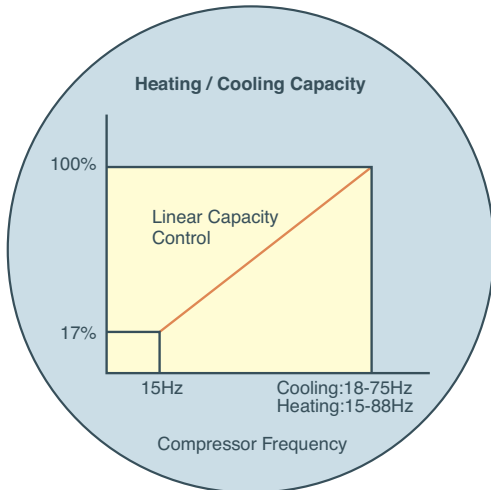

The outdoor unit combinations comprise one unit for P72-P120 models (R2 and Y-Series), two units for P144-P240 models systems (R2 and Y-Series) and three units for P264-P360 models (Y-Series only). Each outdoor unit model features one INVERTER-driven compressor, making simple and highly reliable control possible.

Not only does it allow low starting currents, the INVERTER-driven compressor also provides precise indoor comfort and adapts to the air-conditioning load as needed.

Easy maintenance

R2-Series systems allow an indoor unit to be serviced, while other indoor units within the same piping system are still in operation. Note that this does not apply to all situations and proper procedures must be followed when servicing any equipment.

Additional Features

Adjustable high static pressure, standard

R2-, Y- and H2i™ Y-Series feature adjustable static pressure up to 0.24" W.G., ideal and flexible for any type of application.

Static pressure setting is adjustable by changing a dip switch making it ideal and flexible for any type of application. Default setting is 0" W.G. with options 0.12 and 0.24" W.G.

Long line length

The modular chassis for both the R2- and Y-Series outdoor units allows for an increased line length to the connected indoor units. Up to a total combined length of refrigerant piping up to 2,624 feet for R2-Series and up to 3,280 feet for Y-Series one way.

Back-up and outdoor unit rotation



Back-up Function

(combined module systems)

The combined modular outdoor unit design ensures an exceptionally high level of reliability by utilizing a back-up function, which can be easily operated in the unlikely case of a malfunction from an indoor unit remote controller.

Back-up Function

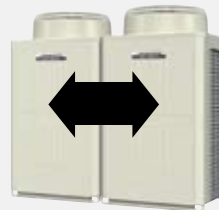

Rotation Function

Rotation Function

(combined module systems)

Running outdoor units alternatively with the 'Rotation Function', the system is able to ensure an optimum product life cycle for both of its component units.

System check

Ensuring simple and easy maintenance, system tests are available to check wiring, sensors and the refrigerant amount.



CITY MULTI® R2-Series: The First Two-pipe Heat Recovery System that Simultaneously Cools and Heats

The R2-Series simultaneously cools and heats different zones within a building to provide energy-saving, heat-recovery operation through the use of the BC Controller. The R2-Series can support up to 50 indoor units. New modular units feature a compact chassis, smaller installation footprint, low operating sound, easy piping and maintenance design, and are lightweight. **R2-Series systems are available in both 208/230V and 460V up to 20 tons for different applications.**



The CITY MULTI R2-Series offers the ultimate in freedom and flexibility. Cool one zone while heating another. Set up zones to maximize simultaneous operation: interior/perimeter or eastern/western exposure. Each zone gets the cooling or heating that is needed at any time.

CITY MULTI R2-Series Variable Refrigerant Flow Zoning (VRFZ) systems offer the ultimate in enhanced comfort and effective energy usage. R2-Series outdoor unit modules use a single INVERTER-driven compressor (Variable Frequency Drive) per module to provide highly-responsive cooling and heating performance. By responding to indoor and outdoor temperature fluctuations, systems vary power consumption by adjusting the compressor speed to optimize energy usage. The variable-capacity indoor units are controlled by electronic expansion valves, which allows operation only at the levels required to maintain a consistently comfortable indoor environment without wasting energy.

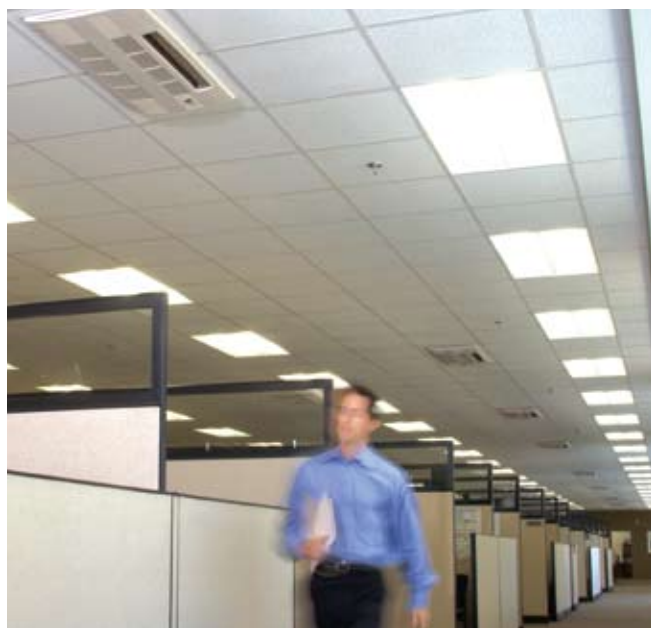

Simultaneous operation

CITY MULTI systems provide simultaneous cooling and heating operation in fall, winter, and spring when the temperature drops below 65° F. So there is a significant number of days when the CITY MULTI R2-Series takes advantage of simultaneous operation, while maximizing comfort. This innovation results in minimizing energy wasted by being expelled outdoors and results in optimum energy usage.

Year-round energy savings

CITY MULTI R2-Series VRFZ systems provide continuous energy savings. During warm weather, R2-Series systems will deliver the precise amount of cooling to the zones requiring conditioning. During cold weather, R2-Series systems provide outstanding heating performance because of the high-speed capabilities of the INVERTER-driven compressor in the outdoor unit.

Most of the year, R2-Series systems operate in partial-load conditions, and the INVERTER-driven compressor runs only at the speeds necessary to provide the required amount of cooling and heating.

Using the two-pipe refrigerant circuit, the system provides true zoning configuration by heating one or more zones, while simultaneously cooling one or more additional zones.

Effective energy usage

The total *applied* capacity of the R2-Series system's indoor units can be up to 150% of the capacity of the outdoor unit by taking advantage of load diversity and simultaneous cooling/heating operation.

CITY MULTI VRFZ systems are able to satisfy a significantly higher building load by efficiently distributing the capacity to the outdoor unit and indoor units while using much less energy.

Simplified connections

With the twinning kit accessory, the modular units easily combine in the field to create a larger capacity system. Only two refrigerant pipes need to be twinned, saving time and materials. Oil and pressure equalization lines aren't needed when combining modules. This also helps to reduce installation cost.



Advantages of CITY MULTI two-pipe systems

The advantages of the two-pipe CITY MULTI system become very obvious when it comes to the installation. The illustration below compares the minimum number of connections required for simultaneous cooling and heating system with four indoor units. The CITY MULTI system requires only 20 connections versus 58 for a three-pipe system. As the number of indoor units grow, so does the two-pipe installations savings, in terms of connections (refrigerant and electrical) as well as maintenance access.

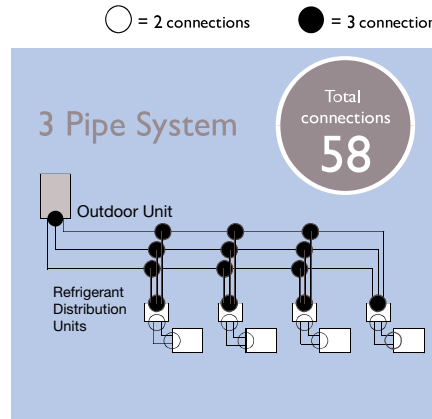
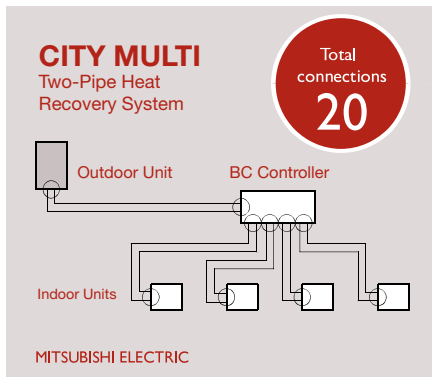

BC Controller

The BC Controller is the technological heart of the CITY MULTI R2-/WR2-Series. It works in unison with the outdoor unit to provide simultaneous cooling and heating, something no other two-pipe system can do.

The Single BC Controller is connected to the outdoor unit by two refrigerant pipes, and to each indoor unit by a series of two pipes,

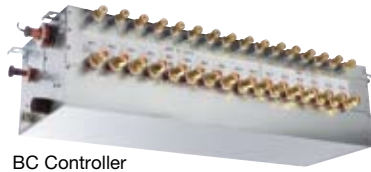

BC Controller

depending on the indoor unit count. The Main BC Controller and up to two optional Sub BC Controllers connect the outdoor unit to the system's indoor units. A Single or Main BC Controller is required for all CITY MULTI R2-/WR2-Series installations. The BC Controller model and size selected depends on how many indoor units will be operated from each outdoor unit, your total capacity requirements, and your installation needs. Each set of ports supports up to 54,000 Btu/h of capacity per indoor unit.

Single BC Controller:

Used when only one BC controller is required. For systems with up to 120,000 Btu/h nominal cooling capacity.

Main BC Controller:

For systems with up to 240,000 Btu/h nominal cooling capacity and when use of Sub BC Controllers is desired.

Sub BC Controller:

Used with a Main BC controller to connect additional indoor units. A maximum of two Sub BC Controllers can be connected to one Main BC Controller per system.

Increased pipe length

The R2-Series system offers flexibility and reduced costs for refrigerant piping. The system may have a maximum total length of refrigerant piping from 1,804 - 2,624 feet one way, depending on outdoor unit model.

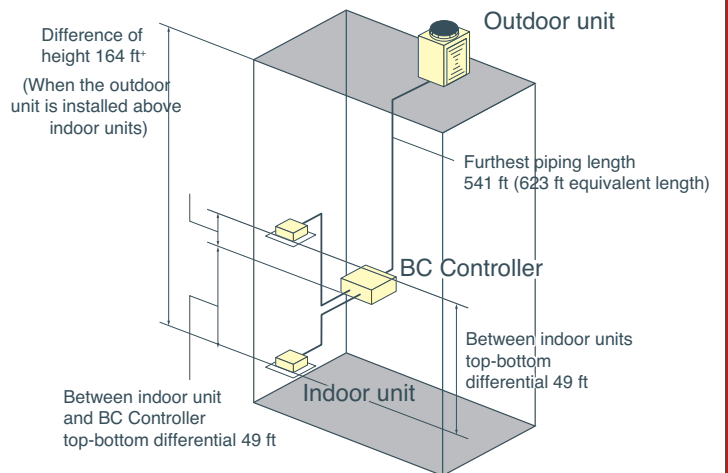

*When the outdoor unit is installed below indoor units than vertical difference is 131 ft

Refrigerant Piping Lengths	Maximum Feet
Total length	1,804 - 2,624
- Maximum total length is dependent on the outdoor unit model and distance between BC controller.	
Maximum allowable length	541 (623 equivalent)
Maximum length between outdoor and single/main BC controller	360
Maximum length between single/main BC controller and indoor	131-196

Vertical differentials between units	Maximum Feet
Indoor/outdoor (outdoor higher)	164*
Indoor/outdoor (outdoor lower)	131
Indoor/BC controller (single/main)	49
- Maximum length between single/main BC controller and indoor is dependent upon the vertical differential between the single/main BC controller and the indoor unit.	
Indoor/indoor	49
Main BC Controller/Sub BC Controller	49

*Can be extended. Ask your local Mitsubishi Electric representative for more details. 11

R2-SERIES SPECIFICATIONS



Model Name		208/230V	PURY-P72THMU-A (-BS)	PURY-P96THMU-A (-BS)	PURY-P120THMU-A (-BS)
		460V	PURY-P72YHMU-A (-BS)	PURY-P96YHMU-A (-BS)	PURY-P120YHMU-A (-BS)
Power Source		208/230V, 3-phase, 60Hz / 460V, 3-Phase, 60Hz			
Capacity *1	Cooling	Btu/h	72,000	96,000	120,000
		kW	5.55	8.35 / 8.27	10.59
		A	15.4 / 7.7	23.2 / 11.6	29.5 / 14.7
	Heating	Btu/h	80,000	108,000	120,000
		kW	6.04	8.66	10.16
		A	16.8 / 8.4	24.1 / 12.0	28.3 / 14.1
Fan	Type x Quantity		Propeller Fan x 1		
	Airflow Rate	CFM	6,550	7,750	7,950
	Direct-drive INVERTER Motor Output	kW	0.92		
	External Static Pressure		Selectable; 0, 0.12 or 0.24" W.G.; factory set to 0" W.G.		
Compressor	Type		INVERTER-driven Scroll Hermetic x1		
	Operating Range		19% to 100%		17% to 100%
	Motor Output	kW	4.4	7.0	8.1
	Crankcase Heater	W	51	57	
	Lubricant		MEL32		
Refrigerant	Type		R410A		
External Finish		Pre-coated Galvanized-steel Sheets (Plus Powder-coating for -BS types) <Munsell No. 5Y 8/1 or Similar>			
Dimensions	Height	In.	65		
	Width	In.	36-1/4	48-1/16	
	Depth	In.	29-15/16		
Net Weight		Pounds	519 / 552	585 / 618	
Sound Pressure Level (As Measured in an Anechoic Room)		dB(A)	58		60
Protection Devices	High Pressure Protection		High-pressure Sensor, High-pressure Switch		
	Compressor/Fan		Overheat Protection, Thermal Switch		
	Inverter		Overheat and Overcurrent Protection		
Refrigerant Pipe Dimensions	Low Pressure (Brazed)	In.	3/4	7/8	1-1/8
	High Pressure (Brazed)	In.	5/8	3/4	
Indoor Unit	Total Capacity		50 to 150% of Outdoor Unit Capacity		
	Quantity		P06-P96/1-18	P06-P96/1-24	P06-P96/1-30
Operating Temperature Range	Cooling		Outdoor: 23° F DB to 109° F DB		
	Heating		Outdoor: -4° F WB to +60° F WB		

Note: Rating Conditions: *1 Cooling: Indoor: 80°F (27°C) DB / 67°F (19°C) WB; Outdoor: 95°F (35°C) DB.
 Heating: Indoor: 70°F (21°C) DB; Outdoor: 47°F (8°C) DB / 43°F (6°C) WB.

-BS indicates Seacoast Protection option.

LIMITED WARRANTY | Five-year warranty on compressor. One-year warranty on parts.

Specifications Are Subject to Change.



Model Name		208/230V		PURY-P144TSHMU-A (-BS) *2 With 2 PURY-P72THMU-A (-BS) *3		PURY-P168TSHMU-A (-BS) *2 With 1 PURY-P72THMU-A (-BS) and 1 PURY-P96THMU-A (-BS) *3		PURY-P192TSHMU-A (-BS) *2 With 2 PURY-P96THMU-A (-BS) *3		PURY-P216TSHMU-A (-BS) *2 With 1 PURY-P96THMU-A (-BS) and 1 PURY-P120THMU-A (-BS) *3		PURY-P240TSHMU-A (-BS) *2 With 2 PURY-P120THMU-A (-BS) *3						
		460V		PURY-P144YSHMU-A (-BS) *2 With 2 PURY-P72YHMU-A (-BS) *3		PURY-P168YSHMU-A (-BS) *2 With 1 PURY-P72YHMU-A (-BS) and 1 PURY-P96YHMU-A (-BS) *3		PURY-P192YSHMU-A (-BS) *2 With 2 PURY-P96YHMU-A (-BS) *3		PURY-P216YSHMU-A (-BS) *2 With 1 PURY-P96YHMU-A (-BS) and 1 PURY-P120YHMU-A (-BS) *3		PURY-P240YSHMU-A (-BS) *2 With 2 PURY-P120YHMU-A (-BS) *3						
Power Source		208/230V, 3-phase, 60Hz / 460V, 3-Phase, 60Hz																
Capacity *1	Cooling	Btu/h	144,000	168,000	192,000	216,000	240,000											
		kW	11.32 *3	14.19 *3	17.04 *3	19.32 *3	21.61 *3											
		A	31.5 / 15.7 *3	39.5 / 19.7 *3	47.5 / 23.7 *3	53.8 / 26.9 *3	60.2 / 30.1 *3											
	Heating	Btu/h	160,000	188,000	200,000	228,000	240,000											
		kW	12.44 *3	15.14 *3	15.85 *3	19.38 *3	20.92 *3											
		A	34.6 / 17.3 *3	42.2 / 21.1 *3	44.2 / 22.1 *3	54.0 / 27.0 *3	58.3 / 29.1 *3											
Fan	Type x Quantity		Refer to PURY-P72THMU-A (-BS) and PURY-P72YHMU-A (-BS) Specifications on page 12		Refer to PURY-P72THMU-A (-BS) / PURY-P96THMU-A (-BS) and PURY-P72YHMU-A (-BS) / PURY-P96YHMU-A (-BS) Specifications on page 12		Refer to PURY-P96THMU-A (-BS) and PURY-P96YHMU-A (-BS) Specifications on page 12		Refer to PURY-P96THMU-A (-BS) / PURY-P120THMU-A (-BS) and PURY-P96YHMU-A (-BS) / PURY-P120YHMU-A (-BS) Specifications on page 12		Refer to PURY-P120THMU-A (-BS) and PURY-P120YHMU-A (-BS) Specifications on page 12							
	Airflow Rate	CFM																
	Direct-drive INVERTER Motor Output	kW																
	External Static Pressure																	
Compressor	Type		Refer to PURY-P72THMU-A (-BS) and PURY-P72YHMU-A (-BS) Specifications on page 12		Refer to PURY-P72THMU-A (-BS) / PURY-P96THMU-A (-BS) and PURY-P72YHMU-A (-BS) / PURY-P96YHMU-A (-BS) Specifications on page 12		Refer to PURY-P96THMU-A (-BS) and PURY-P96YHMU-A (-BS) Specifications on page 12		Refer to PURY-P96THMU-A (-BS) / PURY-P120THMU-A (-BS) and PURY-P96YHMU-A (-BS) / PURY-P120YHMU-A (-BS) Specifications on page 12		Refer to PURY-P120THMU-A (-BS) and PURY-P120YHMU-A (-BS) Specifications on page 12							
	Operating Range												10% to 100%	8% to 100%	9% to 100%	9% to 100%	9% to 00%	
	Motor Output	kW																
	Crankcase Heater	W																
Lubricant																		
Refrigerant	Type		Refer to PURY-P72THMU-A (-BS) and PURY-P72YHMU-A (-BS) Specifications on page 12		Refer to PURY-P72THMU-A (-BS) / PURY-P96THMU-A (-BS) and PURY-P72YHMU-A (-BS) / PURY-P96YHMU-A (-BS) Specifications on page 12		Refer to PURY-P96THMU-A (-BS) and PURY-P96YHMU-A (-BS) Specifications on page 12		Refer to PURY-P96THMU-A (-BS) / PURY-P120THMU-A (-BS) and PURY-P96YHMU-A (-BS) / PURY-P120YHMU-A (-BS) Specifications on page 12		Refer to PURY-P120THMU-A (-BS) and PURY-P120YHMU-A (-BS) Specifications on page 12							
External Finish																		
Dimensions	Height	In.																
	Width	In.																
	Depth	In.																
Net Weight	Pounds		61		62		63											
Sound Pressure Level (As Measured in an Anechoic Room)		dB(A)																
Protection Devices	High Pressure Protection								High-pressure Sensor, High-pressure Switch									
	Compressor/Fan								Overheat Protection, Thermal Switch									
	Inverter		Overheat and Overcurrent Protection															
Refrigerant Pipe Dimensions (Outdoor Units to Twinning Kit) *2	Low Pressure (Braze)	In.	Both Outdoor Units: 3/4		P72THMU: 3/4		Both Outdoor Units: 7/8		P96THMU: 7/8		Both Outdoor Units: 1-1/8							
		P96THMU: 7/8		P120THMU: 1-1/8														
	High Pressure (Braze)	In.	Both Outdoor Units: 5/8		P72THMU: 5/8		Both Outdoor Unit: 3/4											
		P96THMU: 3/4																
Refrigerant Pipe Dimensions (Twinning Kit to Indoor Units) *2	Low Pressure (Braze)	In.	1-1/8															
	High Pressure (Braze)	In.	7/8					1-1/8										
Required Twinning Kit *2	Model		CMY-R100VBK															
	Total Capacity		50 to 150% of Outdoor Unit Capacity															
Indoor Unit	Quantity		P06-P96/1-36	P06-P96/1-42	P06-P96/1-48	P06-P96/2-50 *4	P06-P96/2-50 *4											
	Operating Temperature Range		Cooling: Outdoor: 23° F DB to 109° F DB Heating: Outdoor: -4° F WB to +60° F WB															

*1 *1 Rating Conditions: *1 Cooling: Indoor: 80°F (27°C) DB / 67°F (19°C) WB; Outdoor: 95°F (35°C) DB.

Heating: Indoor: 70°F (21°C) DB; Outdoor: 47°F (8°C) DB / 43°F (6°C) WB.

*2 Twinning Kit is required for combining two or three individual outdoor units in the field for PURY-P-TSHMU combined systems.

*3 Each individual outdoor unit requires a separate electrical connection. Reference electrical data for each individual outdoor unit.

*4 Maximum connectable no. of branch pipes is 48.

-BS indicates Seacoast Protection option.

LIMITED WARRANTY | Five-year warranty on compressor. One-year warranty on parts.

Specifications Are Subject to Change.

NOTES: In systems with considerably long piping runs, the outdoor units may exhibit slightly louder than normal sound pressure levels when in heating mode.

The outdoor twinning kit (low pressure) should be connected to the low pressure side of the outdoor unit. If the connected units are different capacities, the outdoor twinning kit (low pressure) should be installed in the unit with the largest capacity.

BC CONTROLLER SPECIFICATIONS

for R2-Series and WR2-Series Systems (Heat Recovery)



CMB-P-NU-G (Single BC) Specifications

Model Name			CMB-P105NU-G	CMB-P106NU-G	CMB-P108NU-G	CMB-P1010NU-G	CMB-P1013NU-G	CMB-P1016NU-G
Number of Branches			5	6	8	10	13	16
Power Source			208/230V, 1-phase, 60 Hz					
Power Input	Cooling	W	73	86	112	138	178	217
	Heating	W	33	40	53	66	86	106
Current (208/230V)	Cooling	A	0.35/0.32	0.41/0.37	0.54/0.49	0.66/0.60	0.86/0.77	1.04/0.94
	Heating	A	0.16/0.14	0.19/0.17	0.25/0.23	0.32/0.29	0.41/0.37	0.51/0.46
External Finish			Unit: Galvanized steel plate; Drain pan: Pre-coated galvanized sheets plus powder coating					
Dimensions	Height	Inches	11-3/16	11-3/16	11-3/16	11-3/16	11-3/16	11-3/16
	Width	Inches	25-17/32	25-17/32	25-17/32	25-17/32	43-1/4	43-1/4
	Depth	Inches	17-1/32	17-1/32	17-1/32	17-1/32	17-1/32	17-1/32
Net Weight		Pounds	72	76	84	94	126	138
Connectable Outdoor Unit			PURY-P72/96/120THMU-A(-BS), PURY-P72/96/120YHMU-A(-BS), PQRV-P72/96TGMU-A					
Refrigerant Pipe Dimensions	To Outdoor Unit PURY-P72	Low Pressure (in.)	3/4 (Brazed)					
		High Pressure (in.)	5/8 (Brazed)					
	To Outdoor Unit PURY-P96/P108	Low Pressure (in.)	7/8 (Brazed)					
		High Pressure (in.)	3/4 (Brazed)					
	To Outdoor Unit PURY-P126	Low Pressure (in.)	1-1/8 (Brazed)					
		High Pressure (in.)	3/4 (Brazed)					
	To Indoor Unit	Gas Pipe (in.)	5/8 (Flare)					
		Liquid Pipe (in.)	3/8 (Flare)					
Indoor Unit Capacity Connectable to One Branch			54,000 Btu/h or less per branch					
Drain pipe			O.D. 1-1/4"					

Specifications are subject to change.



CMB-P-NU-GA (Main BC) Specifications

Model Name			CMB-P108NU-GA	CMB-P1010NU-GA	CMB-P1013NU-GA	CMB-P1016NU-GA
Number of Branches			8	10	13	16
Power Source			208/230V, 1-phase, 60 Hz			
Power Input	Cooling	W	112	138	178	217
	Heating	W	53	66	86	106
Current (208/230V)	Cooling	A	0.54/0.49	0.66/0.60	0.86/0.77	1.04/0.94
	Heating	A	0.25/0.23	0.32/0.29	0.41/0.37	0.51/0.46
External Finish			Unit: Galvanized steel plate; Drain pan: Pre-coated galvanized sheets plus powder coating			
Dimensions	Height	Inches	11-13/32	11-13/32	11-13/32	11-13/32
	Width	Inches	43-23/32	43-23/32	43-23/32	43-23/32
	Depth	Inches	20-1/2	20-1/2	20-1/2	20-1/2
Net Weight		Pounds	122	132	148	162
Connectable Outdoor Unit			PURY-P72/96/120/144/168/192/216/240T(S)HMU-A(-BS), PURY-P72.96/120/144/168/192/216/240Y(S)HMU-A(-BS), PQRV-P72/96TGMU-A			
Refrigerant Pipe Dimensions	To Outdoor Unit PURY-P72	Low Pressure (in.)	3/4 (Brazed)			
		High Pressure (in.)	5/8 (Brazed)			
	To Outdoor Unit PURY-P73/108	Low Pressure (in.)	7/8 (Brazed)			
		High Pressure (in.)	3/4 (Brazed)			
	To Outdoor Unit PURY-P109/126	Low Pressure (in.)	1-1/8 (Brazed)			
		High Pressure (in.)	3/4 (Brazed)			
	To Outdoor Unit PURY-P127/192	Low Pressure (in.)	1-1/8 (Brazed)			
		High Pressure (in.)	7/8 (Brazed)			
	To Outdoor Unit PURY-P193/240	Low Pressure (in.)	1-1/8 (Brazed)			
		High Pressure (in.)	1-1/8 (Brazed)			
	To Indoor Unit	Gas (in.)	5/8 (Flare)			
		Liquid (in.)	3/8 (Flare)			
	To other BC Controller (Total indoor unit capacity connected to this Sub BC ≤ 72,000 btu/h)	Low Pressure (in.)	3/4 (Brazed)			
		High Pressure (in.)	5/8 (Brazed)			
		Liquid (in.)	3/8 (Brazed)			
	To other BC Controller (Total indoor unit capacity connected to this Sub BC between 73,000-108,000 btu/h)	Low Pressure (in.)	7/8 (Brazed)			
High Pressure (in.)		3/4 (Brazed)				
Liquid (in.)		3/8 (Brazed)				
To other BC Controller (Total indoor unit capacity connected to this Sub BC between 109,000-126,000 btu/h)	Low Pressure (in.)	1-1/8 (Brazed)				
	High Pressure (in.)	3/4 (Brazed)				
	Liquid (in.)	1/2 (Brazed)				
Indoor Unit Capacity Connectable to One Branch			54,000 Btu/h or less per branch			
Drain pipe			O.D. 1-1/4"			

Specifications are subject to change.



CMB-P-NU-GB, HB (Sub BC) Specifications					
Model Name			CMB-P104NU-GB	CMB-P108NU-GB	CMB-P1016NU-HB
Number of Branches			4	8	16
Power Source			208/230V, 1-phase, 60 Hz		
Power Input	Cooling	W	53	106	314
	Heating	W	27	53	157
Current (208/230V)	Cooling	A	0.25/0.23	0.51/0.46	1.17/1.37
	Heating	A	0.13/0.12	0.25/0.23	0.59/0.69
External Finish			Unit: Galvanized steel plate; Drain pan: Pre-coated galvanized sheets plus powder coating		
Dimensions	Height	Inches	11-3/16		
	Width	Inches	25-17/32		43-1/4
	Depth	Inches	17-1/32		
Net Weight		Pounds	62	82	136
Refrigerant Pipe Dimensions	To Indoor Unit	Gas Pipe (in.)	5/8 (Flare)		
		Liquid Pipe (in.)	3/8 (Flare)		
	From other BC controller (Total indoor unit capacity connected to this Sub BC ≤ 72,000 btu/h)	Low Pressure (in.)	3/4 (Brazed)		
		High Pressure (in.)	5/8 (Brazed)		
		Liquid (in.)	3/8 (Brazed)		
	From other BC controller (Total indoor unit capacity connected to this Sub BC between 73,000-108,000 btu/h)	Low Pressure (in.)	7/8 (Brazed)		
		High Pressure (in.)	3/4 (Brazed)		
		Liquid (in.)	3/8 (Brazed)		
	From other BC controller (Total indoor unit capacity connected to this Sub BC between 109,000-126,000 btu/h)	Low Pressure (in.)	1-1/8 (Brazed)		
		High Pressure (in.)	3/4 (Brazed)		
		Liquid (in.)	1/2 (Brazed)		
	From other BC controller (Total indoor unit capacity connected to this Sub BC between 127,000-144,000 btu/h)	Low Pressure (in.)	-	1-1/8 (Brazed)	
		High Pressure (in.)	-	7/8 (Brazed)	
		Liquid (in.)	-	1/2 (Brazed)	
	From other BC controller (Total indoor unit capacity connected to this Sub BC between 145,000-168,000 btu/h)	Low Pressure (in.)	-	1-1/8 (Brazed)	
		High Pressure (in.)	-	7/8 (Brazed)	
Liquid (in.)		-	5/8 (Brazed)		
Indoor Unit Capacity Connectable to One Branch			54,000 Btu/h or less per branch		30,000 Btu/h or less per branch
Drain pipe			O.D. 1-1/4"		

NOTE: CMB-P1016NU-HB only works with PURY-P**THMU-A (-BS) and PURY-P**YHMU-A (-BS) outdoor units.

Specifications are subject to change.

Two-pipe simultaneous operation

High pressure and low pressure decides the compressor frequency and the mode of heat exchanger, and control the amounts of heat exchange.

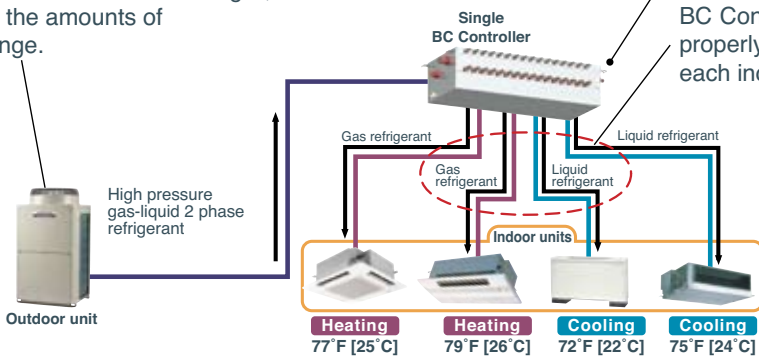

R2/WR2 refrigerant circuit

Gas-liquid 2-phase refrigerant from outdoor unit is divided into gas refrigerant and liquid refrigerant by gas-liquid separator in BC Controller.

BC Controller divides refrigerant to each indoor unit properly in compliance with the operation mode of each indoor unit.

Adjust the refrigerant flow by temperature difference between inlet and outlet.

Meet the demand of
--- cooling / heating flexibly.

Heating=gas refrigerant
Cooling=liquid refrigerant

CITY MULTI® Y-Series: The Two-pipe Zoned System designed for Heat Pump Operation

Y-Series outdoor units are flexible enough to cool or heat up to 50 individual zones, maximizing building design options. New modular units feature a compact chassis, smaller installation footprint, low operating sound, easy piping and maintenance design, and are lightweight. **Y-Series units are available in both 208/230V and 460V up to 30 tons for different applications.**



Design flexibility

Flexibility is the key with the CITY MULTI Y-Series. The Y-Series, just like the R2-Series, can air condition up to 50 zones intelligently. The Y-Series takes advantage of Mitsubishi Electric's INVERTER technology to deliver the precise amount of cooling or heating to all connected zones. By using T-branches and headers, the Y-Series provides the ultimate in piping design flexibility that is truly simple in application.

The ultimate in zoning: just the way you imagined

The CITY MULTI Y-Series uses a two-pipe system with a wide variety of indoor units and individual zone controllers to provide the ultimate zoning system. Headers and T-branches simplify the piping design and provide design freedom for placement of both piping and indoor units. **The BC Controller is not used for Y-Series installations.** Individual zones are managed by remote controllers placed in each zone or by the centralized controller.

Intelligent energy usage

The highly responsive INVERTER technology and customized individual zones of the CITY MULTI Y-Series provide year-round savings. In the warm summer, the Y-Series provides exceptional zoned cooling, and in the cold winter months the INVERTER-driven compressor provides outstanding heating performance.

CITY MULTI systems, in combination with Mitsubishi Electric's TG-2000 integrated system software configured with Tenant Billing, are able to monitor and log each zone's energy usage via a networked PC.

Larger projects, more options

New to the modular outdoor unit design specifications is the option for either a 208/230V, 3-Phase, 60Hz or a 460V, 3-Phase, 60Hz power source. Another feature is the larger capacities for the larger projects, up to 30 tons, and an increased number of connectable indoor units to 50 with increased line lengths. These capabilities increase the range of potential applications that CITY MULTI VRFZ systems can be specified for by an architect, engineer or building owner.

Increased pipe length

The Y-Series two-pipe system offers great piping design flexibility. Two pipes run from the Y series outdoor unit to connect up to 50 indoor units via simple T-branches, headers, or combination of both. A Y-Series system may have a total combined length of refrigerant piping up to 3,280 feet one way. The farthest distance between the Y-Series outdoor unit and any one of the 50 indoor units is 541 feet. The outdoor unit can be placed 164* feet vertically above the lowest indoor unit or 131 feet vertically below the highest indoor unit. The Y-Series offers exceptional line lengths that will accommodate just about any commercial application, including multi-story office buildings, universities, and many, many others.

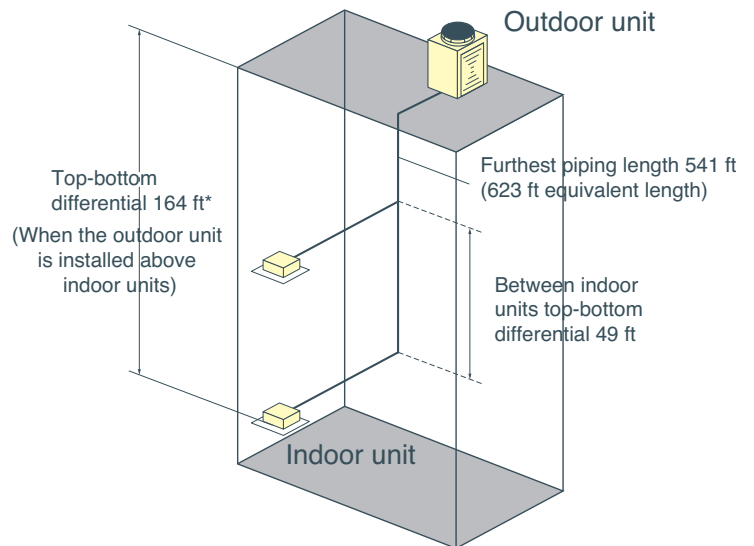

Refrigerant Piping Lengths	Maximum Feet
Total length.....	3,280
Maximum allowable length.....	541 (623 equivalent)
Farthest indoor unit from first branch.....	131*

Vertical differentials between units	Maximum Feet
Indoor/outdoor (outdoor higher).....	164*
Indoor/outdoor (outdoor lower).....	131
Indoor/indoor.....	49

*Can be extended. Ask your local Mitsubishi Electric representative for more details.

Y-SERIES SPECIFICATIONS



Model Name		208/230V	PUHY-P72THMU-A (-BS)	PUHY-P96THMU-A (-BS)	PUHY-P120THMU-A (-BS)
		460V	PUHY-P72YHMU-A (-BS)	PUHY-P96YHMU-A (-BS)	PUHY-P120YHMU-A (-BS)
Power Source		208/230V, 3-Phase, 60Hz / 460V, 3-Phase, 60Hz			
Capacity *1	Cooling	Btu/h	72,000	96,000	120,000
		kW	5.27	8.42	10.11
		A	14.6 / 7.3	23.4 / 11.7	28.1 / 14.0
	Heating	Btu/h	80,000	108,000	120,000
		kW	5.68	8.63	9.26
		A	15.8 / 7.9	24.0 / 12.0	25.8 / 12.9
Fan	Type x Quantity		Propeller Fan x 1		
	Airflow Rate	CFM	7,050		7,950
	Direct-drive INVERTER Motor Output	kW	0.92		
	External Static Pressure		Selectable; 0, 0.12 or 0.24" W.G.; factory set to 0" W.G.		
Compressor	Type		INVERTER-driven Scroll Hermetic x1		
	Operating Range		18% to 100%	13% to 100%	18% to 100%
	Motor Output	kW	5.1	6.8	8.8
	Crankcase Heater	W	51		57
	Lubricant		MEL32		
Refrigerant	Type	R410A			
External Finish		Pre-coated Galvanized-steel Sheets (Plus Powder-coating for -BS types) <Munsell No. 5Y 8/1 or Similar>			
Dimensions	Height	In.	65		
	Width	In.	36-1/4	48-1/16	
	Depth	In.	29-15/16		
Net Weight	Pounds	441 / 474		541 / 574	
Sound Pressure Level (As Measured in an Anechoic Room)	dB(A)	58		60	
Protection Devices	High Pressure Protection		High-pressure Sensor, High-pressure Switch		
	Compressor/Fan		Overheat Protection, Thermal Switch		
	Inverter		Overheat and Overcurrent Protection		
Refrigerant Pipe Dimensions	Low Pressure (Braze)	In.	3/4	7/8	
	High Pressure (Braze)	In.	3/8	3/8; If total length is ≥ 295', then 1/2	
Indoor Unit	Total Capacity		50 to 130% of Outdoor Unit Capacity		
	Quantity		P06-P96/1-15	P06-P96/1-20	P06-P96/1-26
Operating Temperature Range	Cooling		Outdoor: 23° F DB to 109° F DB		
	Heating		Outdoor: -4° F WB to +60° F WB		

Note: Rating Conditions: *1 Cooling: Indoor: 80°F (27°C) DB / 67°F (19°C) WB; Outdoor: 95°F (35°C) DB.
 Heating: Indoor: 70°F (21°C) DB; Outdoor: 47°F (8°C) DB / 43°F (6°C) WB.
 -BS indicates Seacoast Protection option.
 LIMITED WARRANTY | Five-year warranty on compressor. One-year warranty on parts.

Specifications Are Subject to Change.

Y-SERIES SPECIFICATIONS (continued)



Model Name			208/ 230V	PUHY-P144TSHMU-A (-BS) *2	PUHY-P168TSHMU-A (-BS) *2	PUHY-P192TSHMU-A (-BS) *2	PUHY-P216TSHMU-A (-BS) *2	PUHY-P240TSHMU-A (-BS) *2				
			With 2 PUHY-P72THMU-A (-BS) *3			With 1 PUHY-P72THMU-A (-BS) and 1 PUHY-P96THMU-A (-BS) *3	With 1 PUHY-P72THMU-A (-BS) and 1 PUHY-P120THMU-A (-BS) *3	With 1 PUHY-P96THMU-A (-BS) and 1 PUHY-P120THMU-A (-BS) *3	With 2 PUHY-P120THMU-A (-BS) *3			
			460V	PUHY-P144YSHMU-A (-BS) *2	PUHY-P168YSHMU-A (-BS) *2	PUHY-P192YSHMU-A (-BS) *2	PUHY-P216YSHMU-A (-BS) *2	PUHY-P240YSHMU-A (-BS) *2				
Power Source			208/230V, 3-phase, 60Hz / 460V, 3-Phase, 60Hz									
Capacity *1	Cooling	Btu/h	144,000	168,000	192,000	216,000	240,000					
		kW	10.87 *3	14.11 *3	15.84 *3	19.09 *3	20.82 *3					
		A	30.3 / 15.1 *3	39.3 / 19.6 *3	44.1 / 22.0 *3	53.2 / 26.6 *3	58.0 / 29.0 *3					
	Heating	Btu/h	160,000	188,000	200,000	228,000	240,000					
		kW	11.69 *3	14.73 *3	15.38 *3	18.42 *3	19.07 *3					
		A	32.6 / 16.3 *3	41.0 / 20.5 *3	42.8 / 21.4 *3	51.3 / 25.6 *3	53.1 / 26.5 *3					
Fan	Type x Quantity		Refer to PUHY-P72THMU-A (-BS) / PUHY-P72YHMU-A (-BS) Specifications on page 17	Refer to PUHY-P72THMU-A (-BS) / PUHY-P96THMU-A (-BS) and PUHY-P72YHMU-A (-BS) / PUHY-P96YHMU-A (-BS) Specifications on page 17	Refer to PUHY-P72THMU-A (-BS) / PUHY-P120THMU-A (-BS) and PUHY-P72YHMU-A (-BS) / PUHY-P120YHMU-A (-BS) Specifications on page 17	Refer to PUHY-P96THMU-A (-BS) / PUHY-P120THMU-A (-BS) and PUHY-P96YHMU-A (-BS) / PUHY-P120YHMU-A (-BS) Specifications on page 17	Refer to PUHY-P120THMU-A (-BS) and PUHY-P120YHMU-A (-BS) Specifications on page 17					
	Airflow Rate	CFM										
	Motor Output	kW										
	External Static Pressure											
Compressor	Type		Refer to PUHY-P72THMU-A (-BS) / PUHY-P72YHMU-A (-BS) Specifications on page 17	Refer to PUHY-P72THMU-A (-BS) / PUHY-P96THMU-A (-BS) and PUHY-P72YHMU-A (-BS) / PUHY-P96YHMU-A (-BS) Specifications on page 17	Refer to PUHY-P72THMU-A (-BS) / PUHY-P120THMU-A (-BS) and PUHY-P72YHMU-A (-BS) / PUHY-P120YHMU-A (-BS) Specifications on page 17	Refer to PUHY-P96THMU-A (-BS) / PUHY-P120THMU-A (-BS) and PUHY-P96YHMU-A (-BS) / PUHY-P120YHMU-A (-BS) Specifications on page 17	Refer to PUHY-P120THMU-A (-BS) and PUHY-P120YHMU-A (-BS) Specifications on page 17					
	Operating Range							9% to 100%	8% to 100%	6% to 100%	6% to 100%	8% to 100%
	Direct-drive INVERTER Motor Output	kW										
	Crankcase Heater	W										
	Lubricant											
Refrigerant	Type		Refer to PUHY-P72THMU-A (-BS) / PUHY-P72YHMU-A (-BS) Specifications on page 17	Refer to PUHY-P72THMU-A (-BS) / PUHY-P96THMU-A (-BS) and PUHY-P72YHMU-A (-BS) / PUHY-P96YHMU-A (-BS) Specifications on page 17	Refer to PUHY-P72THMU-A (-BS) / PUHY-P120THMU-A (-BS) and PUHY-P72YHMU-A (-BS) / PUHY-P120YHMU-A (-BS) Specifications on page 17	Refer to PUHY-P96THMU-A (-BS) / PUHY-P120THMU-A (-BS) and PUHY-P96YHMU-A (-BS) / PUHY-P120YHMU-A (-BS) Specifications on page 17	Refer to PUHY-P120THMU-A (-BS) and PUHY-P120YHMU-A (-BS) Specifications on page 17					
External Finish												
Dimensions	Height	In.										
	Width	In.										
	Depth	In.										
Net Weight	Pounds											
Sound Pressure Level (As Measured in an Anechoic Room)	dB(A)		61	62.5	63.0							
Protection Devices	High Pressure Protection		High-pressure Sensor, High-pressure Switch									
	Compressor/Fan		Overheat Protection, Thermal Switch									
	Inverter		Overheat and Over-current Protection									
Refrigerant Pipe Dimensions (Outdoor Units to Twinning Kit) *2	Low Pressure (Brazed)	In.	Both Outdoor Units: 3/4	P72THMU: 3/4		Both Outdoor Units: 7/8						
	High Pressure (Brazed)	In.	Both Outdoor Units: 3/8	P96THMU: 7/8	P120THMU: 7/8	P96THMU: 3/8	Both Outdoor Units: 1/2					
				P120THMU: 1/2								
Refrigerant Pipe Dimensions (Twinning Kit to Indoor Units) *2	Low Pressure (Brazed)	In.	1-1/8									
	High Pressure (Brazed)	In.	1/2	5/8								
Required Twinning Kit *2	Model		CMY-Y100VBK									
	Total Capacity		50 to 130% of Outdoor Unit Capacity									
Indoor Unit	Quantity		P06-P96/1-31	P06-P96/1-36	P06-P96/1-41	P06-P96/2-46	P06-P96/2-50					
	Operating Temperature Range		Outdoor: 23° F DB to 109° F DB									
Cooling		Outdoor: -4° F WB to +60° F WB										
Heating												

*1 Rating Conditions: *1 Cooling: Indoor: 80°F (27°C) DB / 67°F (19°C) WB; Outdoor: 95°F (35°C) DB. Heating: Indoor: 70°F (21°C) DB; Outdoor: 47°F (8°C) DB / 43°F (6°C) WB.

*2 Twinning Kit is required for combining two or three individual outdoor units in the field for PUHY-P-TSHMU combined systems.

*3 Each individual outdoor unit requires a separate electrical connection. Reference electrical data for each individual outdoor unit.

-BS indicates Seacoast Protection option. LIMITED WARRANTY | Five-year warranty on compressor. One-year warranty on parts.

Specifications Are Subject to Change.



Model Name			208/ 230V	PUHY-P264TSHMU-A (-BS) *2	PUHY-P288TSHMU-A (-BS) *2	PUHY-P312TSHMU-A (-BS) *2	PUHY-P336TSHMU-A (-BS) *2	PUHY-P360TSHMU-A (-BS) *2
			460V	With 2 PUHY-P72THMU-A (-BS) and 1 PUHY-P120THMU-A (-BS) *3	With 1 PUHY-P72THMU-A (-BS), 1 PUHY-P96THMU-A (-BS), and 1 PUHY-P120THMU-A *3	With 1 PUHY-P72THMU-A (-BS) and 2 PUHY-P120THMU-A (-BS) *3	With 1 PUHY-P96THMU-A (-BS) and 2 PUHY-P120THMU-A (-BS) *3	With 3 PUHY-P120THMU-A (-BS) *3
Power Source			208/230V, 3-phase, 60Hz / 460V, 3-Phase, 60Hz					
Capacity *1	Cooling	Btu/h	264,000	288,000	312,000	336,000	360,000	
		kW	21.28 *3	24.52 *3	26.25 *3	29.50 *3	31.23 *3	
		A	59.3 / 29.6 *3	68.3 / 34.1 *3	73.2 / 36.6 *3	82.2 / 41.1 *3	87.1 / 43.5 *3	
	Heating	Btu/h	280,000	308,000	320,000	348,000	360,000	
		kW	21.23 *3	24.27 *3	24.92 *3	27.96 *3	28.61 *3	
		A	59.2 / 29.6 *3	67.6 / 33.8 *3	69.5 / 34.7 *3	77.9 / 38.9 *3	79.7 / 39.8 *3	
Fan	Type x Quantity		Refer to PUHY-P72THMU-A (-BS) / PUHY-P120THMU-A (-BS) and PUHY-P72YHMMU-A (-BS) / PUHY-P120YHMMU-A (-BS) Specifications on page 17	Refer to PUHY-P72THMU-A (-BS) / PUHY-P96THMU-A (-BS) / PUHY-P120THMU (-BS) and PUHY-P72YHMMU-A (-BS) / PUHY-P96YHMMU-A (-BS) / PUHY-P120YHMMU-A (-BS) Specifications on page 17	Refer to PUHY-P72THMU-A (-BS) / PUHY-P120THMU-A (-BS) and PUHY-P72YHMMU-A (-BS) / PUHY-P120YHMMU-A (-BS) Specifications on page 17	Refer to PUHY-P96THMU-A (-BS) / PUHY-P120THMU-A (-BS) and PUHY-P96YHMMU-A (-BS) / PUHY-P120YHMMU-A (-BS) Specifications on page 17	Refer to PUHY-P120THMU-A (-BS) and PUHY-P120YHMMU-A (-BS) Specifications on page 17	
	Airflow Rate	CFM						
	Direct-drive INVERTER Motor Output	kW						
	External Static Pressure							
Compressor	Type		Refer to PUHY-P72THMU-A (-BS) / PUHY-P96THMU-A (-BS) / PUHY-P120THMU (-BS) and PUHY-P72YHMMU-A (-BS) / PUHY-P96YHMMU-A (-BS) / PUHY-P120YHMMU-A (-BS) Specifications on page 17	5% to 100%	5% to 100%	4% to 100%	4% to 100%	6% to 100%
	Operating Range							
	Motor Output	kW						
	Crankcase Heater	W						
	Lubricant							
Refrigerant	Type							
External Finish								
Dimensions	Height	In.	Refer to PUHY-P72THMU-A (-BS) / PUHY-P96THMU-A (-BS) and PUHY-P72YHMMU-A (-BS) / PUHY-P120YHMMU-A (-BS) Specifications on page 17	Refer to PUHY-P72THMU-A (-BS) / PUHY-P96THMU-A (-BS) / PUHY-P120THMU (-BS) and PUHY-P72YHMMU-A (-BS) / PUHY-P96YHMMU-A (-BS) / PUHY-P120YHMMU-A (-BS) Specifications on page 17	Refer to PUHY-P72THMU-A (-BS) / PUHY-P120THMU-A (-BS) and PUHY-P72YHMMU-A (-BS) / PUHY-P120YHMMU-A (-BS) Specifications on page 17	Refer to PUHY-P96THMU-A (-BS) / PUHY-P120THMU-A (-BS) and PUHY-P96YHMMU-A (-BS) / PUHY-P120YHMMU-A (-BS) Specifications on page 17	Refer to PUHY-P120THMU-A (-BS) and PUHY-P120YHMMU-A (-BS) Specifications on page 17	
	Width	In.						
	Depth	In.						
Net Weight		Pounds						
Sound Pressure Level (As Measured in an Anechoic Room)		dB(A)	63.5		64.5		65	
Protection Devices	High Pressure Protection		High-pressure Sensor, High-pressure Switch					
	Compressor/Fan		Overheat Protection, Thermal Switch					
	Inverter		Overheat and Over-current Protection, Thermal Switch					
Refrigerant Pipe Dimensions (Outdoor Units to Twinning Kit) *2	Low Pressure (Braze)	In.	P72THMU: 3/4			All Outdoor Units: 7/8		
		In.	P120THMU: 7/8	P96, 120THMU: 7/8	P120THMU: 7/8			
	High Pressure (Braze)	In.	P72THMU: 3/8	P72, 96THMU: 3/8	P72THMU: 3/8	P96THMU: 3/8	All Outdoor Units: 1/2	
			P120THMU: 1/2					
Refrigerant Pipe Dimensions (Twinning Kit to Indoor Units) *2	Low Pressure (Braze)	In.	1-3/8			1-5/8		
	High Pressure (Braze)	In.	3/4					
Required Twinning Kit *2	Model		CMY-Y300VBK					
Indoor Unit	Total Capacity		50 to 130% of Outdoor Unit Capacity					
	Quantity		P06-P96/2-50	P06-P96/2-50	P06-P96/2-50	P06-P96/2-50	P06-P96/2-50	
Operating Temperature Range	Cooling		Outdoor: 23° F DB to 109° F DB					
	Heating		Outdoor: -4° F WB to +60° F WB					

*1 Rating Conditions: *1 Cooling: Indoor: 80°F (27°C) DB / 67°F (19°C) WB; Outdoor: 95°F (35°C) DB. Heating: Indoor: 70°F (21°C) DB; Outdoor: 47°F (8°C) DB / 43°F (6°C) WB.

*2 Twinning Kit is required for combining two or three individual outdoor units in the field for PUHY-P-TSHMU combined systems.

*3 Each individual outdoor unit requires a separate electrical connection. Reference electrical data for each individual outdoor unit.

-BS indicates Seacoast Protection option. LIMITED WARRANTY | Five-year warranty on compressor. One-year warranty on parts.

Specifications Are Subject to Change.



The heat pump as you knew it is history.

The Hyper-Heating INVERTER (H2i™) technology* is exclusively from Mitsubishi Electric and is available in select CITY MULTI® VRFZ models. The cooling and heating success of our INVERTER heat pump systems is well documented. But we did not stop there. We decided to redefine the heat pump even more.



Imagine sitting toasty warm inside while it is -13° F outside or realizing full heating capacity at 5° F outdoor ambient. Now open your eyes and see the H2i outdoor units. **H2i delivers heat, and lots of it.**

With our INVERTER-driven heat pump systems you use energy effectively while maintaining the ideal comfort level. Now, with the integration of the innovative H2i technology, you experience the added benefit of year-round comfort with a single system, even on the coldest days of the year. This technology exclusive to Mitsubishi comes appropriately at a time when fuel costs and energy usage are at an all-time high.

- **Exceptional 100% heating capacity, even at 5° F outdoor**
- **Tremendous 75% heating capacity at -13° F outdoor**
- **Extended comfort performance and longer interval between defrost time can provide up to four hours of heating in one continuous cycle**

Hyper-Heating Inverter vs. Other Units
% Heating Capacity vs. Outdoor Temperature

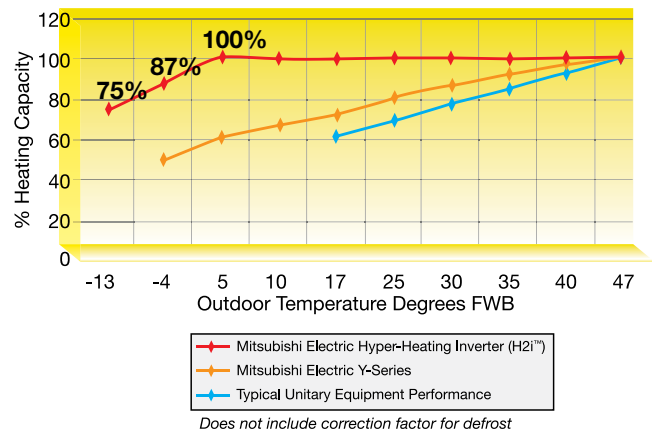

Warm air quickly!

On start up a special circuit assures that normally dormant refrigerant quickly enters the conditioning cycle. This process rapidly increases the mass flow rate in the system, which quickly provides comfortable discharge temperatures from the indoor units.

Even at -13° F outdoor temperature the H2i system can provide 100° F discharge air temperature from the indoor unit. And at 5° F outdoor temperature and above, the discharge temperature reaches an impressive 110° F with a 40° F temperature rise.

Indoor Unit Heating Discharge Temperature
PKFY-P24 with 70° F entering air

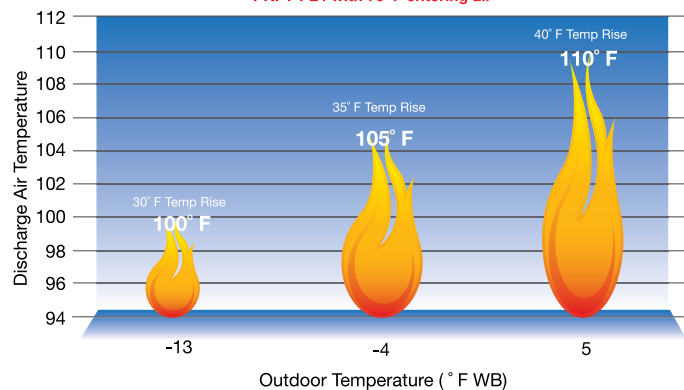

The technology behind the unequaled comfort

The Hyper-Heating INVERTER outdoor unit uses flash technology which recollects heat energy that is normally wasted in the flash process at the outdoor coil. This process helps the H2i systems overcome issues commonly associated with conventional heat pumps such as decreases in low-side pressure, refrigerant mass flow rate and operational capacity.

The patent pending flash process cools the compressor allowing higher speeds at a lower outdoor temperature without overheating. This also allows for an increase in mass flow rate in the system providing phenomenal heating performance at low temperatures.

Setting a new standard in performance

The Hyper-Heating INVERTER Y-Series combines the ultimate in application flexibility and powerful cooling and heating capabilities to deliver precise comfort control to multiple zones of a commercial or institutional building. The outdoor units deliver full-sized performance from a more compact, space-saving design. A compact design equates to easier transportation and installation. The INVERTER-driven scroll compressor delivers the precise amount of comfort to the zones as required. Now, with its expanded heating capabilities, the CITY MULTI H2i Y-Series provides year-round comfort even in extreme climates.

H2i Y-SERIES SPECIFICATIONS



OUTDOOR UNITS

Model Name			PUHY-HP72THMU-A (-BS)		PUHY-HP96THMU-A (-BS)		PUHY-HP144TSHMU-A (-BS) *2		PUHY-HP192TSHMU-A (-BS) *2			
			With 2 PUHY-HP72THMU-A (-BS)		With 2 PUHY-HP96THMU-A (-BS)							
Power Source			208/230V, 3-phase, 60Hz									
Capacity *1	Cooling	Btu/h	72,000	96,000	144,000	192,000						
	Heating	Btu/h	80,000	108,000	160,000	216,000						
Power Input	Cooling	kW	5.90	8.73	12.15 *3	17.98 *3						
	Heating	kW	6.28	9.13	12.94 *3	18.81 *3						
Current (208/230)	Cooling	A	18.2-16.5	27.0-24.4	37.5-33.9 *3	55.5-50.2 *3						
	Heating	A	19.4-17.6	28.2-25.5	40.0-36.1 *3	58.1-52.5 *3						
Fan	Type x Quantity		Propeller Fan x 1									
	Airflow Rate	CFM	7,950									
	Direct-drive INVERTER Motor Output	kW	0.92									
	External Static Pressure		Selectable: 0, 0.12 or 0.24" W.G.; factory set to 0" W.G.									
Compressor	Type		INVERTER-driven Scroll Hermetic x1									
	Motor Output	kW	5.3	6.7	Refer to PUHY-HP72THMU-A (-BS) Specifications						Refer to PUHY-HP96THMU-A (-BS) Specifications	
	Crankcase Heater	W	57									
	Lubricant		MEL32									
Type		R410A										
External Finish Color			Pre-coated Galvanized Sheets (Plus Powder-coating for -BS types) <Munsell No. 5Y 8/1 or Similar>									
Dimensions	Height	Inches	65									
	Width	Inches	36-1/4									
	Depth	Inches	29-15/16									
Net Weight		Pounds	486									
Sound Pressure Level (As Measured in an Anechoic Room)		dB(A)	56 (61 in Heating at -5° F Outdoor Temperature)	57 (62 in Heating at -5° F Outdoor Temperature)	59 (64 in Heating at -5° F Outdoor Temperature)	60 (65 in Heating at -5° F Outdoor Temperature)						
Protection Devices	High Pressure Protection		High-pressure Sensor, High-pressure Switch									
	Compressor/Fan		Discharge Thermo, Over-current Protection									
	Inverter		Overheat and Over-current Protection, Thermal Switch									
Refrigerant Pipe Dimensions (Outdoor Units to Indoor Units)	Low Pressure	Inches	3/4 (Brazed + Flare)	7/8 (Brazed)	N/A							
	High Pressure	Inches	1/2 (Brazed + Flare)									
Refrigerant Pipe Dimensions (Outdoor Units to Twinning Kit) *2	Low Pressure	Inches	N/A		Both ODUs: 3/4 (Brazed + Flare) *2		Both ODUs: 7/8 (Brazed) *2					
	High Pressure	Inches			Both ODUs: 3/8 (Brazed + Flare) *2		Both ODUs: 3/8 (Brazed + Flare) *2					
Refrigerant Pipe Dimensions (Twinning Kit to Indoor Units) *2	Low Pressure	Inches	N/A		1-1/8 (Brazed)							
	High Pressure	Inches			5/8 (Brazed)							
Required Twinning Kit *2	Model		CMY-Y100VBK2									
Indoor Unit	Total Capacity		50 to 130% of Outdoor Unit Capacity									
	Quantity		P06-P72/1-13	P06-P96/1-16	P06-P96/1-22	P06-P96/1-24						
Operating Temperature Range	Cooling		Outdoor: 23° F D.B. to 109° F D.B.									
	Heating		Outdoor: -13° F W.B. to +60° F W.B.									

*1 Rating conditions (cooling)-Indoor: D.B. 26.7° C (80° F), W.B. 19.4° C (67° F); Outdoor: D.B. 35° C (95° F). Rating conditions (heating)-Indoor: D.B. 21.1° C (70° F); Outdoor: D.B. 8.3° C (47° F), W.B. 6.1° C (43° F).

*2 Twinning Kit CMY-Y100VBK2 is required for combining two individual outdoor units in the field for PUHY-HP-TSHMU combined systems. Piping dimensions from the Twinning Kit to the Indoor Units are High Pressure: 5/8 In. Brazed; Low Pressure: 1-1/8 In. Brazed.

*3 Each individual outdoor unit requires a separate electrical connection. Reference electrical data for each individual outdoor unit.

-BS indicates Seacoast Protection option. LIMITED WARRANTY I Five-year warranty on compressor. One-year warranty on parts.

Specifications Are Subject to Change.

CITY MULTI® S-Series: Heat Pump solutions in the home or small office

The CITY MULTI S-Series is a single-phase heat pump system perfect for light commercial or large residential applications. Available in 36,000 or 48,000 Btu/h, the S-Series can provide cooling or heating for up to eight individual zones.



The CITY MULTI S-Series for homes and small offices offers all the features and benefits of our large commercial CITY MULTI Y-Series. The S-Series Solution features a single-phase outdoor unit with Variable Refrigerant Flow Zoning (VRFZ) technology and CITY MULTI Controls Network (CMCN) to cool or heat all zones with a variety of indoor unit styles. The compact outdoor unit utilizes R410A refrigerant and an INVERTER-driven compressor to use energy effectively. A maximum of eight CITY MULTI indoor units can be connected with up to 130% connected capacity, depending on diversity. CITY MULTI Controls Network intelligently manages the CITY MULTI building comfort solution through zone controllers and system controllers and optionally through a networked PC to manage individual comfort and to provide the ultimate building comfort solution.

Blue Fin treatment

The standard anti-corrosion Blue Fin treatment of the heat exchanger is especially effective in protecting the aluminum fins from pollution damage, such as smog and environmental pollens, which reduce the capacity and life expectancy of the unit. All CITY MULTI R410A outdoor units have been treated with Blue Fin prior to leaving the factory.



Additional protection of the frame and other component materials on all outdoor units is available as an option, as indicated on the model suffix number with a '-BS'.



S-Series two-pipe cooling or heating system

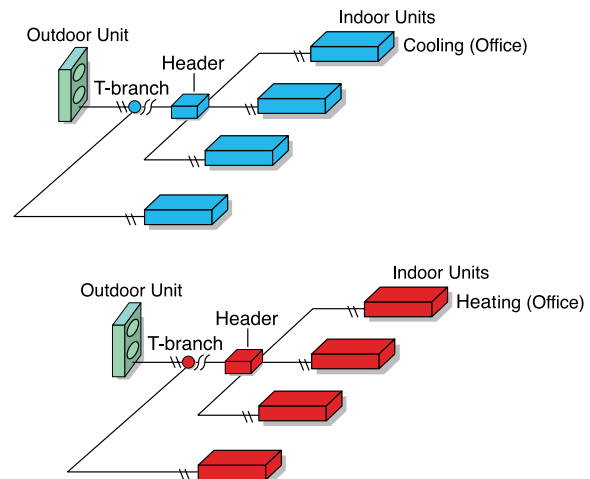

Easy, flexible installation

The S-Series outdoor unit is easy to install and can be accessed for service through both a front and side panel. The unit's compact dimensions and easy accessibility allow multiple units to be stacked side-by-side in tight areas, saving valuable space and resources.

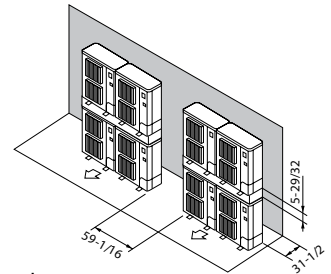



Model Name			PUMY-P36NHMU(-BS)	PUMY-P48NHMU(-BS)
Power Source			208/230V, 1-phase, 60Hz	
Capacity *1	Cooling	Btu/h	36,000	48,000
	Heating	Btu/h	40,000	54,000
Power Input	Cooling	kW	3.22	4.97
	Heating	kW	2.93	4.88
Current (208-230V)	Cooling	A	14.2-15.7	24.0-21.7
	Heating	A	12.9-14.2	23.6-21.3
Fan	Type x Quantity		Propeller Fan x 2	
	Airflow Rate	CFM	3,530	
	Motor Output	kW	0.086 x 2	
Compressor	Type		INVERTER-driven Scroll Hermetic	
	Motor Output	kW	2.4	
	Crankcase Heater	W	-	
	Lubricant		FV50S	
Refrigerant			R410A	
External Finish			Galvanized Sheets (plus Powder Coating for -BS Model) Munsell 3Y 7.8/1.1	
Dimensions	Height	Inches	53-3/16	
	Width	Inches	37-7/16	
	Depth	Inches	13	
Net Weight		Pounds	287	
Sound Pressure Levels (As Measured in an Anechoic Room)		dB(A)	49/51	50/52
Protection Devices	High Pressure Protection		High Pressure Sensor, High Pressure Switch	
	Compressor/Fan		Discharge Thermo and Over-current Detection/Overheat and Voltage Protection	
	Inverter		Over-current/Overheat Protection	
Refrigerant Pipe Dimensions	Low Pressure	Inches	5/8 Flare	
	High Pressure	Inches	3/8 Flare	
Indoor Unit	Total Capacity		50 - 130% of Outdoor Unit Capacity	
	Quantity		P06-36/1-6	P06-P54/1-8
Operating Temperature Range	Cooling		Outdoor: 23° FDB ~ 115° FDB; 50° FDB ~ 115° FDB if connecting PKFY-P06/08 Indoor Unit	
	Heating		Outdoor: 0° FWB ~ 60° FWB	

Note: Rating Conditions: *1 Cooling: Indoor: 80°F (27°C) DB / 67°F (19°C) WB; Outdoor: 95°F (35°C) DB.

Heating: Indoor: 70°F (21°C) DB; Outdoor: 47°F (8°C) DB/ 43°F (6°C) WB.

-BS indicates seacoast protection option.

Specifications Are Subject to Change.

PUMY-P-NHMU Energy Efficiencies

Model	Indoor Unit Type	SEER	HSPF
PUMY-P36NHMU(-BS)	Non-ducted	13.60	8.60
	Ducted and Non-ducted	13.33	8.30
	Ducted	13.05	8.05
PUMY-P48NHMU (-BS)	Non-ducted	14.40	8.70
	Ducted and Non-ducted	14.10	8.50
	Ducted	13.85	8.35

CITY MULTI® W-Series: Water-Source Systems that Simultaneously Cool and Heat or provides Heat Pump Operation

W-Series units combine the convenience of water-source systems with VRFZ technology. These units are easily installed indoors, which means that system performance efficiency is independent of outdoor ambient temperatures. The W-Series includes WR2 models for simultaneous cooling and heating, and WY models as powerful heat pumps.



Now you can control temperature in every room, on every floor, in every building with Mitsubishi Electric's CITY MULTI systems. It's an innovative concept that is transforming the way the industry approaches building design, construction, and renovation; it's based on the understanding that every building has its own unique characteristics and challenges. The CITY MULTI VRFZ building comfort solution gives you the freedom to customize a solution that fits your building like a tailored suit fits a person. As usage patterns and building requirements change, the systems can be adapted to fit these new needs.

W-Series systems from CITY MULTI use water as a heat exchange medium and are intended to be installed inside, rather than outside a building. Zone cooling and heating is controlled by refrigerant piped between water-source unit, BC controller (R2-Series) or manifold (Y-series) and indoor units. W-Series systems can be designed with a wide selection of indoor model configurations and controllers. Indoor units can be monitored and operated individually with remote controllers, up to 50 from one central controller, or up to 2,000 using the TG2000 software. And the CITY MULTI Controls Network (CMCN) integrates with LonWorks® and BACnet® for integrated systems control of the entire building.

Applications include multi-story office buildings, government buildings, military buildings, medical facilities, nursing homes, schools and universities, hotels, resorts, casinos and multi-family dwellings.

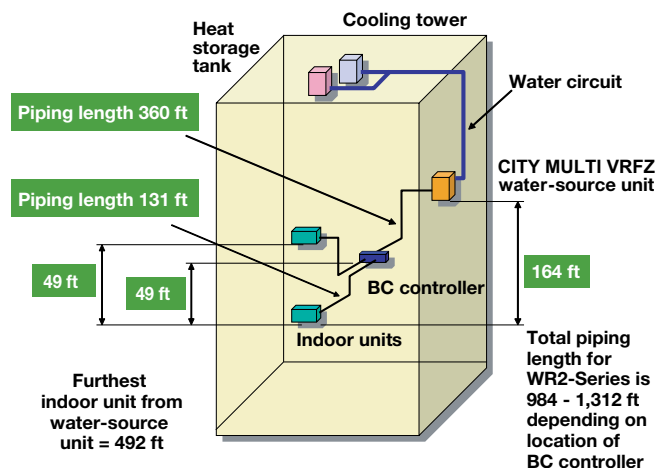

Typical closed-loop installations

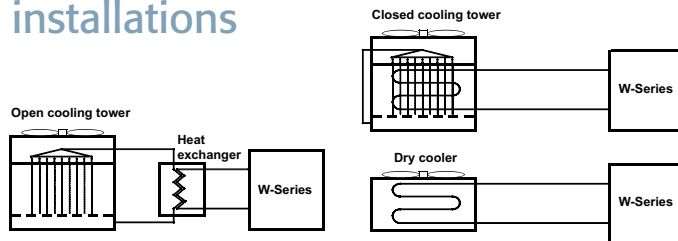

Closed-loop cooling towers recommended

Double heat recovery

The double-heat recovery feature of the WR2-Series helps control energy that would normally be rejected to the atmosphere. First, within the system, energy is absorbed in units providing cooling. The energy is redirected by refrigerant to units that are in heating mode. Secondly, energy can be recovered between systems through the water loop. For example, a system providing primarily cooling is rejecting heat to the water loop. This energy could then be utilized by systems providing primarily heating.

Double Heat Recovery with WR2-Series

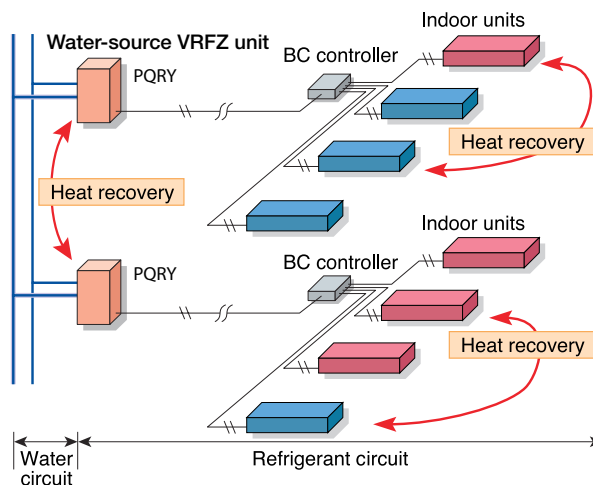

Unit Exterior



Unit Interior

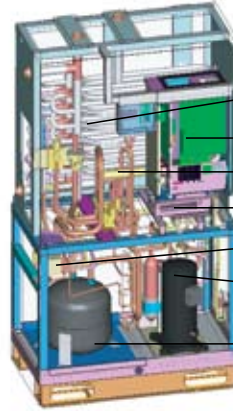

- Multi-circuited tube-in-tube condenser
- Control panel
- Reversing valve
- Inverter cooler
- Condenser circuit control valve block
- INVERTER-driven scroll compressor
- Suction accumulator

Building Example

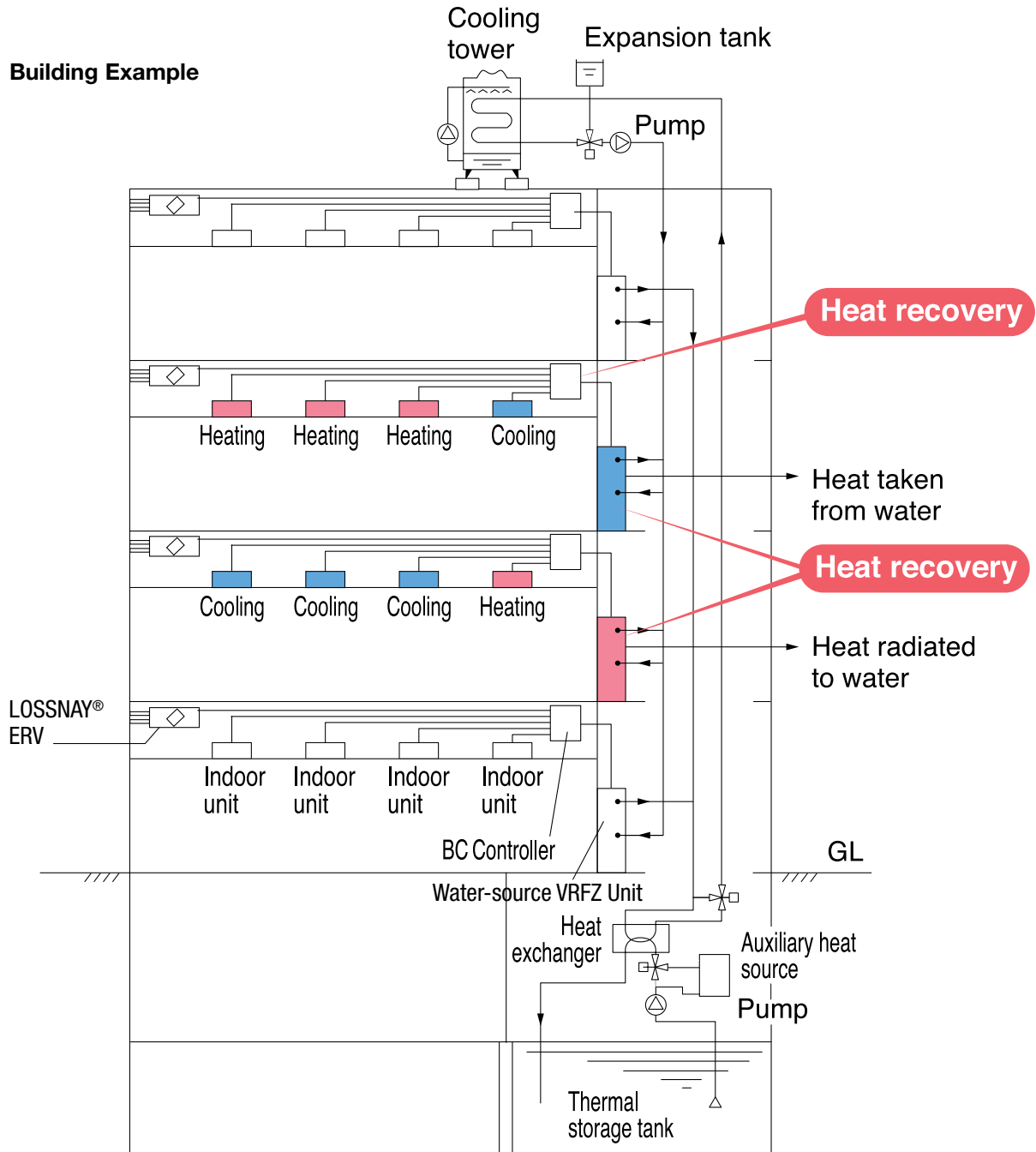

*The water circuit is closed-loop.



WR2-Series Heat Recovery Water-Source Unit (Requires BC Controller)

Model			PQRY-P72TGMU-A	PQRY-P96TGMU-A
Power Source			208-230V, 3-phase, 60Hz	
Capacity *1	Cooling	Btu/h	72,000	96,000
	Heating	Btu/h	85,000	107,000
Power Input	Cooling	kW	5.25	6.95
	Heating	kW	5.44	6.84
Current (208/230V)	Cooling	A	16.19 - 14.64	21.43 - 19.38
	Heating	A	16.77 - 15.17	21.09 - 19.07
Compressor	Type		INVERTER-driven Scroll Hermetic	
	Motor Output	kW	5.0	6.0
	Crankcase Heater	W	57 (230V)	57 (230V)
	Lubricant		MEL32	
Circulating Water	Water Flow Rate	GPM (L/s)	20.1 (1.3)	25.4 (1.6)
	Pressure Drop	Feet (psi)	4.6 (2)	6.9 (3)
	Operation Volume Range	GPM (L/m)	17.2 - 29.9 (65.1 - 113.2)	19.8 - 31.7 (75 - 120)
Refrigerant	Type		R410A	
External Finish			Hot-dip Galvanized-steel Sheets	
Dimensions	Height	Inches	70-7/8	
	Width	Inches	39	
	Depth	Inches	21-11/16	
Net Weight		Pounds	567	574
Sound Pressure Level (As Measured in an Anechoic Room)		dB(A)	46	47
Protection Devices	High-pressure Protection		High-pressure Sensor, High-pressure Switch	
	Compressor		Overcurrent Protection, Overheat Protection	
	Inverter		Overcurrent Protection, Overheat Protection	
Refrigerant Pipe Dimensions	Low Pressure (Brazed)	Inches	3/4	7/8
	High Pressure (Brazed)	Inches	5/8	3/4
Indoor Unit	Total Capacity		50-150% of Outdoor Unit Capacity	
	Model / Quantity		P06-P96 / 1-15	P06-P96 / 1-19
Operating Temperature Range	Cooling		Indoor: 59° to 75° F WB (15° to 24° C WB)	
	Heating		Indoor: 59° to 81° F DB (15° to 27° C DB)	
Circulating Water Temperature Range	Cooling		50° to 113° F (10° to 45° C)	
	Heating		50° to 113° F (10° to 45° C) 59° to 113° F (15° to 45° C) when total indoor unit capacity exceeds 130% of the water-source unit	

Note: Rating Conditions

*1 Cooling: Indoor: 80°F (27°C) DB / 67°F (19°C) WB; Water Temperature: 85°F (29°C)

Heating: Indoor: 70°F (21°C) DB; Water Temperature: 70°F (21°C)

Specifications Are Subject to Change.



WY-Series Heat Pump Water-Source Unit

Model			PQHY-P72TGMU-A	PQHY-P96TGMU-A
Power Source			208-230V, 3-phase, 60Hz	
Capacity *1	Cooling	Btu/h	72,000	96,000
	Heating	Btu/h	85,000	107,000
Power Input	Cooling	kW	5.25	6.95
	Heating	kW	5.44	6.84
Current (208/230V)	Cooling	A	16.19 - 14.64	21.43 - 19.38
	Heating	A	16.77 - 15.17	21.09 - 19.07
Compressor	Type		INVERTER-driven Scroll Hermetic	
	Motor Output	kW	5.0	6.0
	Case Heater	W	57 (230V)	
	Lubricant		MEL32	
Circulating Water	Water Flow Rate	GPM (L/s)	20.1 (1.3)	25.4 (1.6)
	Pressure Drop	Feet (psi)	4.6 (2)	6.9 (3)
	Operation Volume Range	GPM (L/m)	17.2 - 29.9 (65.1 - 113.2)	19.8 - 31.7 (75 - 120)
Dimensions	Height	Inches	70-7/8	
	Width	Inches	39	
	Depth	Inches	21-11/16	
Net Weight		Pounds	587	594
Sound Pressure Level (As Measured in an Anechoic Room)		dB(A)	46	47
Protection Devices	High-pressure Protection		High-pressure Sensor, High-pressure Switch	
	Compressor		Overcurrent Protection, Overheat Protection	
	Inverter		Overcurrent Protection, Overheat Protection	
Refrigerant Pipe Dimensions	Low Pressure	Inches	3/4 Braze	7/8 Braze
	High Pressure	Inches	3/8 Flare	
Indoor Unit	Total Capacity		50-130% of Outdoor Unit Capacity	
	Model / Quantity		P06-P96 / 1-13	P06-P96 / 1-16
Operating Temperature Range	Cooling		Indoor: 59° to 75° F WB (15° to 24° C WB)	
	Heating		Indoor: 59° to 81° F DB (15° to 27° C DB)	
Circulating Water Temperature Range	Cooling		50° to 113° F (10° to 45° C)	
	Heating		50° to 113° F (10° to 45° C)	

Note: Rating Conditions

*1 Cooling: Indoor: 80°F (27°C) DB / 67°F (19°C) WB; Water Temperature: 85°F (29°C)
 Heating: Indoor: 70°F (21°C) DB; Water Temperature: 70°F (21°C)

Specifications Are Subject to Change.

Multiple choices for indoor units

In today's modern building practices, the interior mechanical components are all designed for ultimate comfort and functionality. Aesthetics are also an important aspect of that comfort.

CITY MULTI VRFZ systems offer many sleek styles of ductless or ducted indoor units for various applications. Each indoor unit gives you ultimate zoning flexibility in each space. All are compatible with the R2-Series, Y-Series, H2i™ Y-Series, W-Series and S-Series outdoor units.

PKFY: Wall-mounted

The PKFY wall-mounted indoor unit is very quiet with sound ratings as low as 32 dB(A). The seven sizes available for the PKFY models are 6,000, 8,000, 12,000, 15,000, 18,000, 24,000 and 30,000 Btu/h. This style of indoor unit is well-suited for hotels, assisted living facilities, offices, residences and other applications where wall space is available.



PCFY: Ceiling-suspended

THE PCFY is a ceiling-suspended indoor unit. Four models are available in capacities of 15,000, 24,000, 30,000 and 36,000 Btu/h. The PCFY's auto vane swings the conditioned air and distributes it throughout the room. This model is ideal for restaurants, classrooms, and stores.



PLFY: Ceiling-recessed cassette with up to four-way airflow

The PLFY is our ceiling-recessed type indoor unit with a two-, three-, or four-way airflow option and is available in two styles. These units give you discreet individual room control and four fan speed settings. They can be installed in a lay-in tile or drywall ceiling. The unit can be serviced by an access point in the corner pocket panel on all four corners.



The PLFY-NBMU units have a built-in, drain-lift mechanism with 33 inches of condensation lift. They have four-way independent vane motor control, a wider air stream than previous models and feature an optional i-see™ sensor to measure floor

temperature in real time to provide better management of the sensible temperature. Six models are available in capacities of 12,000, 15,000, 18,000, 20,000, 24,000 and 36,000 Btu/h. PLFY-NCMU units are specifically designed to fit inside of a ceiling grid for added installation and design convenience. The three sizes available for the PLFY-NCMU are 8,000, 12,000, 15,000 and 18,000 Btu/h. PLFY models are well-suited for office buildings, school classrooms, computer server rooms, and other applications where at least 12 inches of space is available above the ceiling.

PDFY and PEFY: Ceiling-concealed ducted

The PDFY and PEFY are concealed-type, ducted indoor units available in standard, low profile and alternating high static styles.



They are installed above the ceiling and allow multiple outlets to be ducted from them. The compact design allows maximum flexibility for air conditioning hard-to-reach zones or for zones that are larger in size. The PDFY and PEFY are extremely quiet. Capacities range from 6,000 to 96,000 Btu/h. This style of indoor unit is well-suited for office buildings, schools, hotels, assisted-living facilities, residences and other applications where ceiling space is available and the most discreet mechanical system is desired.

PFFY: Floor-standing

The PFFY floor-mounted models are available as an exposed or concealed indoor unit. These two styles are available in six capacities: 6,000, 8,000, 12,000, 15,000, 18,000 and 24,000 Btu/h. The PFFY-NEMU requires no finish work and is perfect for any application, especially schools, office buildings, and hotels. The PFFY-NRMU is a concealed floor-mounted unit that practically disappears in the room.

PMFY: Ceiling-recessed cassette with one-way airflow

The PMFY is a ductless, one-way, ceiling-recessed cassette indoor unit that can be connected to ventilation air. This unit is very easy to install and is offered in four capacities: 6,000, 8,000, 12,000 and 15,000 Btu/h. The PMFY model is designed for use in areas that cannot support ductwork or lack the sufficient space to support wall-mounted units.



Floor-standing Exposed
PFFY-NEMU



Floor-standing Concealed
PFFY-NRMU



PVFY: Vertical Air Handler

The PVFY vertical air handler is designed for closet or attic applications. The side drain pan makes it possible to use in a horizontal, left facing, position. With all the components, including a linear expansion valve (LEV) and controls pre-mounted within the cabinet for easy installation, this unit is ideally suited for use in retrofit and new building applications.

Customize your CITY MULTI building comfort solution

All models are quiet, easy to maintain and provide the ultimate in comfort. The chart below illustrates the capacity size for each model.

Capacity Code	Nominal Btu/h	6,000	8,000	12,000	15,000	18,000	24,000	27,000	30,000	36,000	48,000	54,000	72,000	96,000
Wall-mounted PKFY-P-N*MU-E		●	●	●	●	●	●		●					
Ceiling-recessed Cassette PLFY-P-NBMU-E				●	●	●	●		●	●				
Ceiling-recessed Cassette PLFY-P-NCMU-E			●	●	●									
Ceiling-recessed Cassette PMFY-P-NBMU-E		●	●	●	●									
Ceiling-suspended PCFY-P-NGMU-E					●		●		●	●				
Ceiling-concealed (ducted) PDFY-P-NMU-E		●	●	●	●	●	●	●	●	●	●			
Ceiling-concealed (ducted low-profile) PEFY-P-NMSU-E		●	●	●	●	●	●							
Ceiling concealed (ducted alternative high-static option) PEFY-P-NMHU-E					●	●	●	●	●	●	●	●	●	●
Floor-standing (exposed/concealed) PFFY-P-NEMU/NRMU-E		●	●	●	●	●	●							
Vertical Air Handler PVFY-P-E00A				●		●	●		●	●	●	●		

Elegant design and compact dimensions ideal for offices, classrooms, and residential uses.



PKFY-P-NAMU-E



PKFY-P-NGMU-E



PKFY-P-NFMU-E

Capacity range: 6,000 to 30,000 Btu/h

A wide selection for your design and performance needs

Whatever the size or shape of your room, there is a Mitsubishi Electric PKFY unit that is just right, delivering the style and performance you demand and deserve. PKFY units mount high on the wall and blend in beautifully into any space. They are compact and lightweight. In addition, they are extremely quiet with one of the lowest sound ratings available. When it comes to comfort, the PKFY auto-vane feature delivers optimal air distribution and uniform temperatures throughout your space. All of this performance and design flexibility comes in a unit that is remarkably easy to install and maintain. The template and back mounting plate shipped with each unit make installation a snap.

Front grille opens for easy filter cleaning

The front grille hinges open easily with no tools needed to gain quick access to the filter. The filter can be removed and cleaned as needed.

Front grille opens for filter access

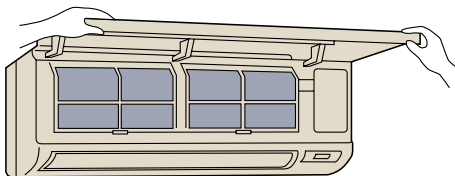

Operation is among the quietest available

The unit incorporates a random-pitch fan to assure quiet operation. The optimal design of the airflow passage features a small fan diameter to allow for a compact installation.

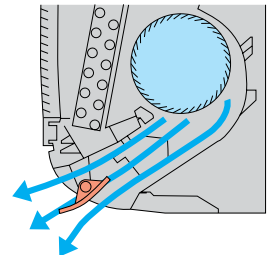

Thanks to practical casing configuration, airflow generated by the fan is distributed uniformly. This design also suppresses condensation.

Swing vane

User selectable vane swing setting with PAR-21MAA and PAR-F27MEA controllers enhances air distribution in the conditioned space.

Five-way piping provides flexibility in selecting installation sites

Refrigerant and drain piping can be connected from the rear, right, base, and left of the unit, providing much greater flexibility for piping and selecting an installation site.

PKFY-P-N*MU-E SPECIFICATIONS



PKFY-P-NAMU-E



PKFY-P-NGMU-E



PKFY-P-NFMU-E

Model Name			PKFY-P06NAMU-E	PKFY-P08NAMU-E	PKFY-P12NGMU-E	PKFY-P15NGMU-E
Power Source			208/230V, 1 Phase, 60Hz			
Cooling Capacity		Btu/h *1	6,000	8,000	12,000	15,000
Heating Capacity		Btu/h *1	6,700	9,000	13,500	17,000
Power Consumption	Cooling	W	30	30	70	70
	Heating	W	30	30	70	70
Current	Cooling	A	0.15	0.15	0.34	0.34
	Heating	A	0.15	0.15	0.34	0.34
External Finish (Munsell No.)			2.60Y 8.66/0.69	2.60Y 8.66/0.69	0.70Y 8.59/0.97	0.70Y 8.59/0.97
Dimensions	Height	Inches	11-5/8	11-5/8	13-13/32	13-13/32
	Width	Inches	32-3/32	32-3/32	39	39
	Depth	Inches	6-1/4	6-1/4	9-9/32	9-9/32
Net Weight	Unit	Pounds	19	19	36	36
Heat Exchanger			Cross Fin (Aluminum Plate Fin and Copper Tube)			
Fan	Type x quantity		Line Flow Fan x 1			
	Airflow Rate *2	CFM	173-184-198-208	173-184-198-208	283-335-371-406	283-335-371-406
	Motor Type		Single Phase Induction Motor			
	Motor Output	W	17	17	30	30
Air Filter			Washable Filter			
Refrigerant Pipe Dimensions	Low Pressure (Flare)	Inches	1/2	1/2	1/2	1/2
	High Pressure (Flare)	Inches	1/4	1/4	1/4	1/4
Drain Pipe Dimension		Inches	I.D. 5/8	I.D. 5/8	I.D. 13/16	I.D. 13/16
Sound Levels *2	Low-Mid1-Mid2-High	dB(A)	32-33-35-36	32-33-35-36	32-36-40-42	32-36-40-42

Model Name			PKFY-P18NFMU-E	PKFY-P24NFMU-E	PKFY-P30NFMU-E
Power Source			208/230V, 1 Phase, 60Hz		
Cooling Capacity		Btu/h *1	18,000	24,000	30,000
Heating Capacity		Btu/h *1	20,000	27,000	34,000
Power Consumption	Cooling	W	90	90	120
	Heating	W	90	90	120
Current	Cooling	A	0.44	0.44	0.58
	Heating	A	0.44	0.44	0.58
External Finish (Munsell No.)			3.4Y 7.7/0.8	3.4Y 7.7/0.8	3.4Y 7.7/0.8
Dimensions	Height	Inches	13-13/32	13-13/32	13-13/32
	Width	Inches	55-1/8	55-1/8	66-5/32
	Depth	Inches	9-9/32	9-9/32	9-9/32
Net Weight	Unit	Pounds	53	53	62
Heat Exchanger			Cross Fin (Aluminum Plate Fin and Copper Tube)		
Fan	Type x quantity		Line Flow Fan x 2		
	Airflow Rate *2	CFM	494-636	494-636	777-989
	Motor Type		Single Phase Induction Motor		
	Motor Output	W	45	45	70
Air Filter			Washable Filter		
Refrigerant Pipe Dimensions	Low Pressure (Flare)	Inches	1/2	5/8	5/8
	High Pressure (Flare)	Inches	1/4	3/8	3/8
Drain Pipe Dimension		Inches	I.D. 13/16	I.D. 13/16	I.D. 13/16
Sound Levels *2	Low-High	dB(A)	39-45	39-45	46-49

Note: *1 Cooling / Heating capacity indicates the maximum value at operation under the following conditions:

Cooling: Indoor: 80°F (27°C) DB / 67°F (19°C) WB; Outdoor: 95°F (35°C) DB

Heating: Indoor: 70°F (21°C) DB; Outdoor: 45°F (7°C) DB / 43°F (6°C) WB

*2 Airflow rate / sound levels are at (Low-Mid1-Mid2-High) or (Low-High)

Ventilation Air: Providing sufficient ventilation air is an important part of every building design.

ASHRAE standard 62 provides the minimum air requirements. Also check local codes.

Specifications are subject to change.

Perfect airflow to meet your needs with four-way control.

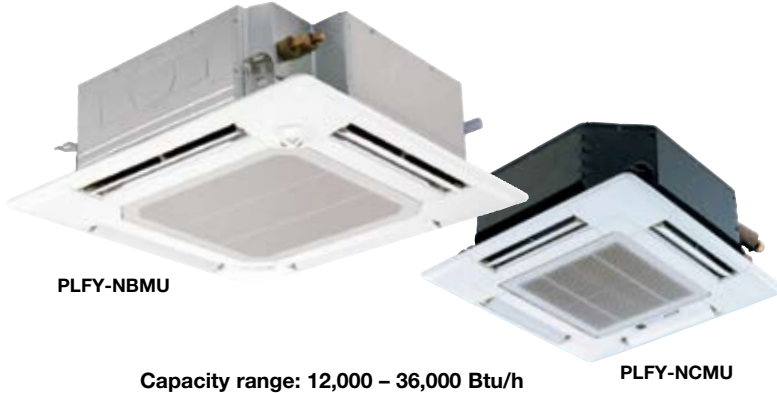

PLFY-Series indoor units offer unequaled flexibility of installation. Their compact ceiling-recessed design makes them easy to install and operate. Their exceptional performance provides excellent air coverage. Two styles are available.

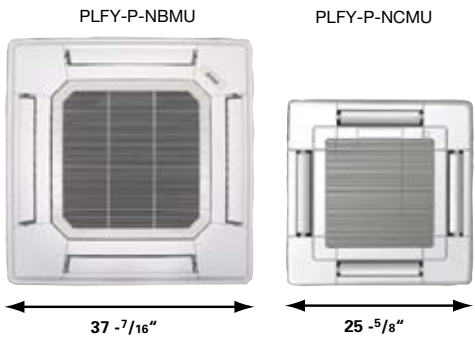

High performance and versatility

The PLFY looks great and works beautifully. The four-way cassette-type unit is compact and recesses easily into a ceiling space so all you see is an attractive, flush-mounted grille. Beneath that elegant exterior is a powerful, high-performance machine with a built-in drain lift-up mechanism. The fan is engineered to provide optimum air distribution with minimal sound. Both styles can bring in outside air into your space, the PLFY-NBMU can also branch over to air condition an adjacent room. The PLFY-NCMU unit is specifically designed to fit within a ceiling grid for ease of installation.

Quiet operation

These powerful indoor units are whisper-quiet, down to 29 dB(A) for the PLFY-NCMU and 27 dB(A) for the PLFY-NBMU.



Ceiling applications

The PLFY-NBMU has a unit height of only 10-1/4" or 11-3/4", depending on the model, and provides great looking installations in low-ceiling areas with very limited space.

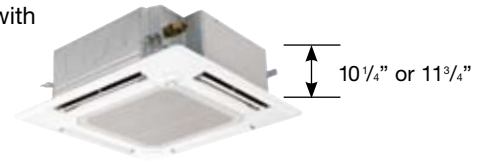

At only 8-3/16" in height and only 22-7/16 x 22-7/16" in width, the PLFY-NCMU makes accessing even the tightest of ceiling installations a possibility. The NCMU's grille is color-matched with the NBMU and blends in well with white drop ceiling tiles.



Customize the airflow pattern to meet your needs

The different airflow patterns provide the best solution for a variety of room layouts and air-conditioning requirements. For extra versatility, you can select from two-, three-, or four-way airflow.

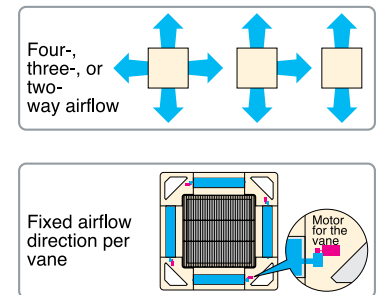

Built-in condensate lift mechanism

The drain piping of the PLFY-NBMU can be positioned anywhere up to 33-1/2 inches from the ceiling's surface, allowing for long piping and versatility. A built-in switch halts operation if an error with the pump occurs, ensuring that no water leaks from the unit.

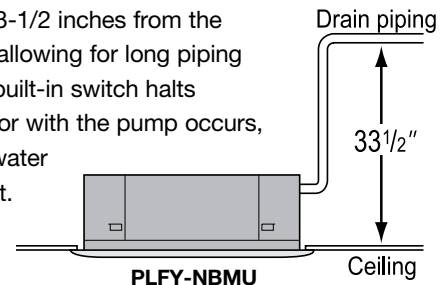

The PLFY-NCMU model has a built-in pump that lifts condensation 20 inches from the ceiling's surface. The unit recognizes when there is a pump failure and safeguards against leaks.

Corner-pocket design simplifies maintenance and installation

Access the unit through the corner pockets equipped on all four corners of the grille to complete installation, maintenance work, and height adjustment.



Easy maintenance, long-life filter

The washable filter provides about 2,500 hours of use in a normal office environment before cleaning is needed. The PLFY-NBMU is also available with an optional multi-function casement that allows for additional ventilation air and better filtration.

ADDITIONAL FEATURES FOR PLFY-NBMU MODELS

Wider air stream

Longer air outlets on the PLFY-NBMU unit deliver wider air streams for improved air distribution and energy savings. This feature means quieter air delivery with fewer drafts and great overall cooling and heating coverage.

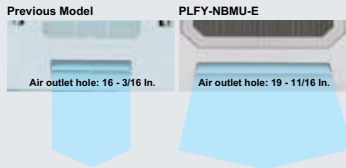

Auto Wave airflow feature (Heating Mode)

In the Heating mode on the PLFY-NBMU, each air outlet vane operates independently, distributing warm air in multiple directions for better room heating.



Independent vane motor control

Each of the four vanes on the PLFY-NBMU can be set by the wired remote controller to operate independently to match the room layout. Specific vane settings include five fixed directions plus swing.



Auto fan speed feature

The PLFY-NBMU unit offers the choice from four set fan speeds, or auto fan speed, to ensure faster achievement of room temperature target. Auto fan speed mode allows the fan to adjust its speed based on the degree of differential between set point and room temperature.

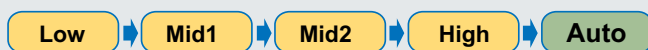

The i-see™ sensor accessory

In addition to the return air temperature, the PLFY-NBMU four-way ceiling cassette with the field installed i-see sensor measures the floor temperature in real time, observing the room vertically for better management of sensible temperature (temperature felt by occupant). The i-see sensor measures the infrared rays generated from the surrounding wall and floor surface at an angle of 360°. The infrared ray energy is converted into a temperature value. The i-see sensor rotates 90° slowly – in five-second intervals – for correct measurement of temperature to cover the full floor space. When combined with the auto fan speed adjustment mode, air can be directed to the farthest corners of the room for enhanced temperature coverage.



i-see sensor detail

i-see Sensor

PLFY-P-NBMU-E SPECIFICATIONS



Model Name			PLFY-P12NBMU-E	PLFY-P15NBMU-E	PLFY-P18NBMU-E
Power Source			208/230V, 1-phase, 60Hz		
Cooling Capacity		Btu/h *1	12,000	15,000	18,000
Heating Capacity		Btu/h *1	13,500	17,000	20,000
Power Consumption	Cooling	W	30	40	50
	Heating	W	20	30	40
Current	Cooling	A	0.22	0.29	0.36
	Heating	A	0.14	0.22	0.29
External Finish Color (Munsell No.)			Grille 6.4Y 8.9/0.4		
Dimensions	Height	Inches	10-3/16		
	Width	Inches	33-3/32		
	Depth	Inches	33-3/32		
Net Weight *2	Unit/Panel	Pounds	49/13		51/13
Heat Exchanger			Cross Fin (Aluminum Plate Fin and Copper Tube)		
Fan	Type x Quantity		Turbo Fan x 1		
	Airflow Rate *3	CFM	388-424-459-494	424-459-494-565	494-530-565-636
	Motor Type		DC Motor		
	Motor Output	kW	0.050		
Air Filter			Polypropylene Honeycomb		
Refrigerant Pipe Dimensions	Low Pressure (Flare)	Inches	1/2		
	High Pressure (Flare)	Inches	1/4		
Condensate Lift Mechanism (Standard)		Inches	33-1/2		
Drain pipe Dimension (O.D.)		Inches	1-1/4		
Sound Pressure Levels (As Measured in an Anechoic Room)*3	(Low-Mid1-Mid2-High)	dB(A)	27-28-29-31	27-28-30-31	28-29-30-32

Model Name			PLFY-P24NBMU-E	PLFY-P30NBMU-E	PLFY-P36NBMU-E
Power Source			208/230, 1-phase, 60Hz		
Cooling Capacity		Btu/h *1	24,000	30,000	36,000
Heating Capacity		Btu/h *1	27,000	34,000	40,000
Power Consumption	Cooling	W	60	70	160
	Heating	W	50	60	150
Current	Cooling	A	0.43	0.51	1.07
	Heating	A	0.36	0.43	1.00
External Finish Color (Munsell No.)			Grille 6.4Y 8.9/0.4		
Dimensions	Height	Inches	10-3/16		11-3/4
	Width	Inches	33-3/32		
	Depth	Inches	33-3/32		
Net Weight *2	Unit/Panel	Pounds	51/13		60/13
Heat Exchanger			Cross Fin (Aluminum Plate Fin and Copper Tube)		
Fan	Type x Quantity		Turbo Fan x 1		
	Airflow Rate *3	CFM	530-565-636-706	565-636-706-777	777-883-989-1,059
	Motor Type		DC Motor		
	Motor Output	kW	0.050		0.120
Air Filter			Polypropylene Honeycomb		
Refrigerant Pipe Dimensions	Low Pressure (Flare)	Inches	5/8		
	High Pressure (Flare)	Inches	3/8		
Condensate Lift Mechanism (Standard)		Inches	33-1/2		
Drain pipe Dimension (O.D.)		Inches	1-1/4		
Sound Pressure Levels (As Measured in an Anechoic Room)*3	(Low-Mid1-Mid2-High)	dB(A)	28-30-32-34	30-32-35-37	35-38-41-43

Note: *1 Cooling / Heating capacity indicates the maximum value at operation under the following conditions:

Cooling: Indoor: 80°F (27°C) DB / 67°F (19°C) WB; Outdoor: 95°F (35°C) DB

Heating: Indoor: 70°F (21°C) DB; Outdoor: 47°F (8°C) DB / 43°F (6°C) WB

*2 Net weight is shown for unit / grille

*3 Airflow rate / sound pressure levels are at (Low-Mid1-Mid2-High).

Ventilation Air: Providing sufficient ventilation air is an important part of every building design. ASHRAE Standard 62 provides the minimum ventilation air requirements. Also check local codes.



Model Name			PLFY-P08NCMU-E	PLFY-P12NCMU-E	PLFY-P15NCMU-E
Power Source			208 230V, 1-phase, 60Hz		
Cooling Capacity		Btu/h *1	8,000	12,000	15,000
Heating Capacity		Btu/h *1	9,000	13,500	17,000
Power Consumption	Cooling	W	50	60	
	Heating	W	50	60	
Current	Cooling	A	0.23	0.28	
	Heating	A	0.23	0.28	
External Finish (Munsell No.)			Grille: White (6.4Y 8.9/0.4)		
Dimensions	Height	Inches	8-3/16		
	Width	Inches	22-7/16		
	Depth	Inches	22-7/16		
Net Weight *2	Unit/Panel	Pounds	34/7	37/7	
Heat Exchanger			Cross Fin (Aluminum Plate Fin and Copper Tube)		
Fan	Type x Quantity		Turbo Fan x 1		
	Airflow Rate *3	CFM	280-320-350	320-350-390	
	Motor Type		Single-phase Induction Motor		
	Motor Output	kW	0.015	0.020	
Air Filter			Polypropylene Honeycomb		
Refrigerant Pipe Dimensions	Low Pressure (Flare)	Inches	1/2		
	High Pressure (Flare)	Inches	1/4		
Condensate Lift Mechanism (Standard)		Inches	19-11/16		
Drain pipe Dimension (O.D.)		Inches	1-1/4		
Sound Pressure Levels (As Measured in an Anechoic Room) *3	(Low-Mid-High)	dB(A)	29-32-38	30-34-39	31-35-40

Note: *1 Cooling / Heating capacity indicates the maximum value at operation under the following conditions:

Cooling: Indoor: 80°F (27°C) DB / 67°F (19°C) WB; Outdoor: 95°F (35°C) DB

Heating: Indoor: 70°F (21°C) DB; Outdoor: 47°F (8°C) DB / 43°F (6°C) WB

*2 Net weight is shown for unit / grille

*3 Airflow rate / sound pressure levels are at (Low-Mid-High).

Ventilation Air: Providing sufficient ventilation air is an important part of every building design. ASHRAE Standard 62 provides the minimum ventilation air requirements. Also check local codes.

Specifications are subject to change.

Optional Accessories for PLFY-P-NBMU-E		
Description	Model	Notes
Air Outlet Shutter Plate (2 pieces)	PAC-SH51SP-E	All PLFY-P-NBMU-E Models
High-efficiency Filter (MERV 10)	PAC-SH59KF-E	All PLFY-P-NBMU-E Models
Multi-function Casement	PAC-SH53TM-E	All PLFY-P-NBMU-E Models
i-see Sensor Corner Panel	PAC-SA1ME-E	All PLFY-P-NBMU-E Models
Wireless Signal Receiver	PAR-SA9FA-E	All PLFY-P-NBMU-E Models

Compact and lightweight one way airflow, perfect for limited ceiling space applications.



Capacity range: 6,000 – 15,000 Btu/h



Ideal for small spaces

The PMFY models are one-way, ceiling-recessed cassette units perfect for shallow ceiling spaces. The PMFY unit moves air in one direction and can introduce ventilation air. It is designed especially for use in areas like hotel rooms that cannot support ductwork or lack sufficient space to allow for wall-mounted units. The PMFY is available in 6,000, 8,000, 12,000 and 15,000 Btu/h capacities.

Compact size for easy installation and maintenance

Unit body size has been standardized for all models at 31-31/32" for easier installation. This profile is one of the smallest of all CITY MULTI ceiling models with a height of only 9-1/16" — ideal for tight locations. Unit weight is only 31 pounds for the main unit and seven pounds for the panel, making this unit one of the lightest in the industry.

Quiet operation

Newly-developed airflow control technology operates as low as 27 dB(A) for industry-leading quiet performance.

Drain lift-up mechanism

The drain pipe can be extended anywhere up to 23-5/8" above the ceiling's surface.

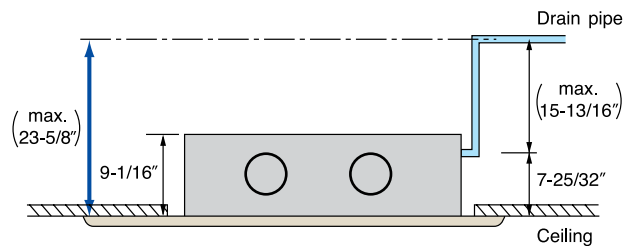

PMFY-P-NBMU-E SPECIFICATIONS



Model			PMFY-P06NBMU-E	PMFY-P08NBMU-E	PMFY-P12NBMU-E	PMFY-P15NBMU-E
Power Source			208/230V, 1 Phase, 60Hz			
Cooling Capacity		Btu/h *1	6,000	8,000	12,000	15,000
Heating Capacity		Btu/h *1	6,700	9,000	13,500	17,000
Power Consumption	Cooling	W	40	40	40	50
	Heating	W	40	40	40	50
Current	Cooling	A	0.20	0.20	0.21	0.26
	Heating	A	0.20	0.20	0.21	0.26
External Finish			Grille: Munsell 0.98Y 8.99/0.63			
Dimensions	Height	Inches	9-1/16	9-1/16	9-1/16	9-1/16
	Width	Inches	31-31/32	31-31/32	31-31/32	31-31/32
	Depth	Inches	15-9/16	15-9/16	15-9/16	15-9/16
Net Weight *2	Unit/Panel	Pounds	31/7	31/7	31/7	31/7
Heat Exchanger			Cross Fin (Aluminum Plate Fin and Copper Tube)			
Fan	Type x quantity		Line Flow Fan x 1			
	Airflow Rate *3	CFM	230-254-283-307	258-283-304-328	258-283-304-328	272-307-340-378
	Motor Type		DC Brushless Motor			
	Motor Output	W	28	28	28	28
Air Filter			PP Honeycomb			
Refrigerant Pipe	Low Pressure (Flare)	Inches	1/2	1/2	1/2	1/2
	High Pressure (Flare)	Inches	1/4	1/4	1/4	1/4
Condensate Lift Mechanism (standard)		Inches	23-5/8	23-5/8	23-5/8	23-5/8
Drain Pipe Dimension		Inches	O.D. 1-1/32	O.D. 1-1/32	O.D. 1-1/32	O.D. 1-1/32
Sound Levels *3	(Low-Mid1-Mid2-High)	dB(A)	27-30-33-35	32-34-36-37	32-34-36-37	33-35-37-39

Note: *1 Cooling / Heating capacity indicates the maximum value at operation under the following conditions:

Cooling: Indoor: 80°F (27°C) DB / 67°F (19°C) WB; Outdoor: 95°F (35°C) DB

Heating: Indoor: 70°F (21°C) DB; Outdoor: 45°F (7°C) DB / 43°F (6°C) WB

*2 Net weight is shown for unit/panel

*3 Airflow rate / sound levels are at (Low-Mid1-Mid2-High)

Ventilation Air: Providing sufficient ventilation air is an important part of every building design. ASHRAE Standard 62 provides the minimum ventilation air requirements. Also check local codes.

Specifications are subject to change.

Ventilation Air for PMFY		
Two 4-inch Diameter Ports		
Model	Airflow (high)	Total Air Capacity Taken from Outside
PMFY-P06NBMU-E	305 CFM	60 CFM
PMFY-P08NBMU-E	325 CFM	60 CFM
PMFY-P12NBMU-E	325 CFM	60 CFM
PMFY-P15NBMU-E	375 CFM	70CFM

Note: Fan assist for intake air required.

Specifications are subject to change.

Compact design ideal for classrooms, restaurants, and stores.



Capacity range: 15,000 – 36,000 Btu/h

Superior performance provides plenty of relief

Powerful cooling and heating performance is what the PCFY style is all about. This easy-to-install, ceiling-suspended unit delivers enough cold or hot air to make any space more comfortable. Manually adjusted, over-sized swing louvers direct the airflow left or right, covering the entire space quietly and efficiently. The dimensions of the compact PCFY style make it perfect for classrooms, restaurants, kitchens, and other large commercial spaces where ovens and other equipment add to an already-taxed cooling or heating load. The PCFY is available in 15,000, 24,000, 30,000 and 36,000 Btu/h capacities.

Quiet, powerful airflow

The appropriate airflow can be selected to enhance air-conditioning efficiency and comfort while operating at a low sound level.

Model Name	Airflow Rate	Sound Level at Low Airflow
PCFY-P15NGMU-E	283-353-388-424	29 dB(A)
PCFY-P24NGMU-E	424-494-565-636	32 dB(A)
PCFY-P30NGMU-E	636-706-812-883	36 dB(A)
PCFY-P36NGMU-E	918-989-1,130-1,236	37 dB(A)



Strong, efficient airflow

The PCFY's auto-vane and wide-range outlet swings the conditioned air and distributes it uniformly to all corners of the room. Accessory filters are also available to increase filtration effectiveness.

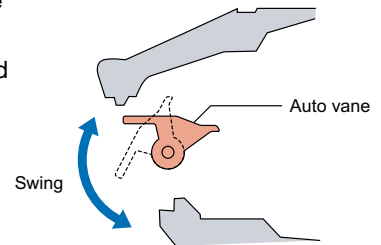

Easy install with direct suspension

The PCFY's direct suspension allows it to be installed onto most ceiling surfaces quickly and securely using only suspension bolts and the PCFY's durable attachment fixture. Plus, a condensate pump can be connected to the PCFY to either the left or the right side of the unit.

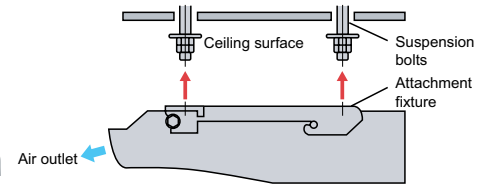



Model Name			PCFY-P15NGMU-E	PCFY-P24NGMU-E	PCFY-P30NGMU-E	PCFY-P36NGMU-E
Power Source			208/230V, 1-phase, 60Hz			
Cooling Capacity	Btu/h *1		15,000	24,000	30,000	36,000
Heating Capacity	Btu/h *1		17,000	27,000	34,000	40,000
Power Consumption	Cooling	W	80	90	230	270
	Heating	W	80	90	230	270
Current	Cooling	A	0.4	0.45	1.12	1.32
	Heating	A	0.4	0.45	1.12	1.32
External Finish Color (Munsell No.)			0.70Y 8.59/0.97			
Dimensions	Height	Inches	8-9/32		10-21/32	
	Width	Inches	39-3/8	51-19/32		63-25/32
	Depth	Inches	26-25/32			
Net Weight	Unit	Pounds	60	75	82	95
Heat Exchanger			Cross Fin (Aluminum Plate Fin and Copper Tube)			
Fan	Type x Quantity		Sirocco Fan x 2	Sirocco Fan x 3		Sirocco Fan x 4
	Airflow Rate *2	CFM	283-353-388-424	424-494-565-636	636-706-812-883	918-989-1,130-1,236
	Motor Type		Single-phase Induction Motor			
	Motor Output	W	0.054	0.070	0.090	0.150
Air Filter			Polypropylene Honeycomb			
Refrigerant Pipe Dimensions	Low Pressure (flare)	Inches	1/2	5/8		
	High Pressure (flare)	Inches	1/4	3/8		
Drain pipe Dimension (O.D.)		Inches	1			
Sound Levels	Low-Mid1-Mid2-High	dB(A) *2	29-33-36-38	32-34-37-39	36-38-41-43	37-39-42-44

Note: *1 Cooling/Heating capacity indicates the maximum value at operation under the following conditions:
 Cooling: Indoor: 80°F (27°C) DB/67°F (19°C) WB; Outdoor: 95°F (35°C) DB
 Heating: Indoor: 70°F (21°C) DB; Outdoor: 47°F (8°C) DB/43°F (6°C) WB
 *2 Airflow rate/sound levels are at (Low-Mid1-Mid2-High) or (Low-High)

Ventilation Air: Providing sufficient ventilation air is an important part of every building design. ASHRAE standard 62 provides the minimum ventilation air requirements. Also check local codes.

Specifications are subject to change.

Flexible design allows elegant interior layout.



Capacity range: 6,000 – 96,000 Btu/h



Designed to be neither seen nor heard, just to perform

The PDFY and PEFY models are high-performance, ceiling-concealed, ducted indoor units. In fact, if it weren't for the constantly comfortable environment these units deliver, you might not even know they were there. The ducted fan coils are designed to be installed above the ceiling, hidden from public view. And they're extremely quiet, with sound ratings as low as 22 dB(A). Hidden doesn't mean hard to reach. In fact, the PDFY and PEFY fan coils are extremely easy to access and maintain according to their application. They open on one side so you can easily access the fan or motor for maintenance. They're also easy to customize to your cooling and heating needs. The external static pressure settings are adjustable to meet different application conditions, such as the use of a high-performance filter. All models support rear return; however, the PDFY models can be field configured for bottom return.

Choice of external static pressure

The additional external static pressure capacity provides flexibility for duct extension, branching, and air outlet configuration. Factory set to 0.24" W.G. can be field adjusted to 0.16" W.G. or 0.40" W.G. to match installed ductwork for PDFY indoor units. The PEFY indoor units are available in a low-profile option and an alternate high-static option for up to 0.80" W.G.

Quiet operation thanks to a specially designed centrifugal fan

Operating Sound Range

		PDFY-P-NMU-E		P06	P08	P12	P15	P18	P24	P27	P30	P36	P48
Sound Level dB(A)	Fan Speed	Low	High	28-36			34-39		30-39	32-40	34-42	38-45	43-47

		PEFY-P-NMSU-E		P06	P08	P12	P15	P18	P24
Sound Level dB(A)	Fan Speed	Low	High	22-28	23-30	23-35	28-33	30-37	30-40

		PEFY-P-NMHU-E		P15	P18	P24	P27	P30	P36	P48	P54	P72	P96
Sound Level dB(A)	Fan Speed	Low	High	34-39	36-41	35-41	38-43	38-44		47		54	

Even smaller compact size (PEFY-P-NMSU)

The PEFY-P**NMSU-E models are more compact than previous models with a height of 7-7/8". Additional features for the PEFY-NMSU include an increased external static pressure (setting available up to 0.20" W.G.), and built-in condensate lift mechanism (21-4/16"). Standard features include brazed refrigerant connections, rear air return and auto fan mode. The unit is extremely quiet, as low as 22 dB(A) and the control panel is located on the opposite side from other ducted models.

This unit is an ideal choice for guest rooms in hotels, dormitories, assisted living centers or any application with tight vertical clearances and minimal ductwork.

PDFY-P-NMU-E SPECIFICATIONS (standard)



Model Name			PDFY-P06NMU-E	PDFY-P08NMU-E	PDFY-P12NMU-E	PDFY-P15NMU-E	PDFY-P18NMU-E
Power Source			208/230V, 1-phase, 60Hz				
Cooling Capacity *1	Btu/h		6,000	8,000	12,000	15,000	18,000
Heating Capacity *1	Btu/h		6,700	9,000	13,500	17,000	20,000
Power Consumption	Cooling	W	120	120	120	150	150
	Heating	W	120	120	120	150	150
Current	Cooling	A	0.61/0.68	0.61/0.68	0.61/0.68	0.77/0.85	0.77/0.85
	Heating	A	0.61/0.68	0.61/0.68	0.61/0.68	0.77/0.85	0.77/0.85
External Finish			Unit: Galvanized Steel Plate				
Dimensions	Height	Inches	11-5/8	11-5/8	11-5/8	11-5/8	11-5/8
	Width	Inches	27-31/32	27-31/32	27-31/32	37-13/16	37-13/16
	Depth	Inches	28-15/16	28-15/16	28-15/16	28-15/16	28-15/16
Net Weight	Unit	Pounds	57	57	60	71	75
Heat Exchanger			Cross Fin (Aluminum Plate Fin and Copper Tube)				
Fan	Type x Quantity		Sirocco Fan x 1	Sirocco Fan x 1	Sirocco Fan x 1	Sirocco Fan x 2	Sirocco Fan x 2
	Airflow Rate *2	CFM	211-229-264-300	211-229-264-300	211-229-264-300	353-388-441-494	353-388-441-494
	Ext. Static Press (230V)	In. W.G.	0.16-0.24-0.40	0.16-0.24-0.40	0.16-0.24-0.40	0.16-0.24-0.40	0.16-0.24-0.40
	Motor Type		Single-phase Induction Motor				
	Motor Output	W	75	75	75	85	85
Air Filter			Standard Filter				
Refrigerant Pipe Dimensions	Low Pressure (Flare)	Inches	1/2	1/2	1/2	1/2	1/2
	High Pressure (Flare)	Inches	1/4	1/4	1/4	1/4	1/4
Drain pipe Dimension		Inches	O.D. 1-1/4				
Sound Pressure Levels *2 (Low-Mid1-Mid2-High)		dB(A)	28-30-33-36			34-36-37-39	

Model Name			PDFY-P24NMU-E	PDFY-P27NMU-E	PDFY-P30NMU-E	PDFY-P36NMU-E	PDFY-P48NMU-E
Power Source			208/230V, 1-phase, 60Hz				
Cooling Capacity *1	Btu/h		24,000	27,000	30,000	36,000	48,000
Heating Capacity *1	Btu/h		27,000	30,000	34,000	40,000	54,000
Power Consumption	Cooling	W	170	180	210	290	390
	Heating	W	170	180	210	290	390
Current	Cooling	A	0.87/0.96	0.94/1.04	1.07/1.19	1.48/1.64	1.99/2.21
	Heating	A	0.87/0.96	0.94/1.04	1.07/1.19	1.48/1.64	1.99/2.21
External Finish			Unit: Galvanized Steel Plate				
Dimensions	Height	Inches	11-5/8	11-5/8	11-5/8	13-7/32	13-7/32
	Width	Inches	45-11/16	45-11/16	45-11/16	59-15/32	59-15/32
	Depth	Inches	28-15/16	28-15/16	28-15/16	30-17/32	30-17/32
Net Weight	Unit	Pounds	86	86	86	115	115
Heat Exchanger			Cross Fin (Aluminum Plate Fin and Copper Tube)				
Fan	Type x Quantity		Sirocco Fan x 2	Sirocco Fan x 2	Sirocco Fan x 2	Sirocco Fan x 2	Sirocco Fan x 2
	Airflow Rate *2	CFM	441-494-565-635	477-547-618-689	494-582-653-741	688-988	847-1200
	Ext. Static Press (230V)	In. W.G.	0.16-0.24-0.40	0.16-0.24-0.40	0.16-0.24-0.46	0.24-0.46-0.60	0.24-0.46-0.60
	Motor Type		Single-phase Induction Motor				
	Motor Output	W	95	95	95	140	190
Air Filter			Standard Filter				
Refrigerant Pipe Dimensions	Low Pressure (Flare)	Inches	5/8	5/8	5/8	5/8	5/8
	High Pressure (Flare)	Inches	3/8	3/8	3/8	3/8	3/8
Drain pipe Dimension		Inches	O.D. 1-1/4				
Sound Pressure Levels *2 (Low-Mid1-Mid2-High)		dB(A)	30-34-36-39	32-36-38-40	34-37-40-42	38-45	43-47

Note: *1 Cooling /Heating capacity indicates the maximum value at operation under the following conditions:
 Cooling: Indoor: 80°F (27°C) DB/67°F (19°C) WB; Outdoor: 95°F (35°C) DB
 Heating: Indoor: 70°F (21°C) DB; Outdoor: 47°F (8°C) DB/43°F (6°C) WB

*2 Airflow rate/sound levels are at (Low-Mid1-Mid2-High) or (Low-High)

Ventilation Air: Providing sufficient ventilation air is an important part of every building design. ASHRAE standard 62 provides the minimum ventilation air requirements. Also check local codes.

Specifications are subject to change.

PEFY-P-NMSU-E SPECIFICATIONS LOW PROFILE

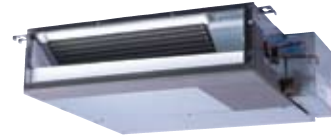

Model Name			PEFY-P06NMSU-E* 1	PEFY-P08NMSU-E	PEFY-P12NMSU-E	PEFY-P15NMSU-E	PEFY-P18NMSU-E	PEFY-P24NMSU-E	
Power Source			208/230V, 1-phase, 60Hz						
Cooling Capacity *2	Btu/h		6,000	8,000	12,000	15,000	18,000	24,000	
Heating Capacity *2	Btu/h		6,700	9,000	13,500	17,000	20,000	27,000	
Power Consumption	Cooling	W	50/50	60/60	70/70		90/90	120/120	
	Heating	W	30/30	40/40	50/50		70/70	100/100	
Current	Cooling	A	0.42/0.41	0.51/0.49	0.56/0.53	0.57/0.55	0.74/0.70	0.98/0.93	
	Heating	A	0.32/0.31	0.41/0.39	0.46/0.43	0.47/0.45	0.64/0.60	0.88/0.83	
External Finish			Galvanized Steel Sheets						
Dimensions	Height	Inches	7-7/8						
	Width	Inches	31-1/8			39		46-7/8	
	Depth	Inches	27-9/16						
Net Weight	Unit	Pounds	42	46	54	62			
Heat Exchanger			Cross Fin (Aluminum Plate Fin and Copper Tube)						
Fan	Type x Quantity		Sirocco Fan x 2			Sirocco Fan x 3		Sirocco Fan x 4	
	Airflow Rate *3	CFM	176-212-247	194-247-317	211-282-370	282-335-388	353-441-529	423-565-706	
	External Static Pressure *4	In.W.G.	0.02-0.06-0.14-0.20						
	Motor Type		DC Brushless Motor						
	Motor Output	W	96						
Air Filter			Polypropylene Honeycomb Fabric (washable)						
Refrigerant Pipe Dimensions	Low Pressure (Brazed)	Inches	1/2					5/8	
	High Pressure (Brazed)	Inches	1/4					3/8	
Condensate Lift Mechanism (standard)	Inches	21-4/16							
Drain pipe Dimensions (O.D.)	Inches	1-1/4							
Sound Pressure Levels *3	Low-Mid-High	dB(A)	22-24-28	23-26-30	23-28-35	28-30-33	30-34-37	30-35-40	

Note: *1 PEFY-P06NMSU-E cannot be used with PUHY/PURY-P-TGMU or PQHY/PQRY-P-TGMU units.

*2 Cooling/Heating capacity indicates the maximum value at operation under the following conditions:

Cooling: Indoor: 80°F (27°C) DB/67°F (19°C) WB; Outdoor: 95°F (35°C) DB.

Heating: Indoor: 70°F (21°C) DB; Outdoor: 47°F (8°C) DB/43°F (6°C) WB.

*3 Airflow rate/sound pressure levels are at (Low-Mid-High).

*4 External static pressure is factory set to 0.06 in.WG.

Ventilation Air: Providing sufficient ventilation air is an important part of every building design.

ASHRAE Standard 63 provides the minimum ventilation air requirements. Also check local codes.

Specifications are subject to change.

PEFY-P-NMHU-E SPECIFICATIONS ALTERNATE HIGH STATIC OPTION



INDOOR UNITS

Model Name			PEFY-P15NMHU-E	PEFY-P18NMHU-E	PEFY-P24NMHU-E	PEFY-P27NMHU-E	PEFY-P30NMHU-E
Power Source			208/230V, 1-phase, 60Hz				
Cooling Capacity *1	Btu/h		15,000	18,000	24,000	27,000	30,000
Heating Capacity *1	Btu/h		17,000	20,000	27,000	30,000	34,000
Power Consumption	Cooling	W	188/207	188/207	245/270	270/297	326/360
	Heating	W	188/207	188/207	245/270	270/297	326/360
Current	Cooling	A	0.96/1.06	0.96/1.06	1.25/1.38	1.37/1.51	1.66/1.83
	Heating	A	0.96/1.06	0.96/1.06	1.25/1.38	1.37/1.51	1.66/1.83
External Finish			Unit: Galvanized Steel Plate				
Dimensions	Height	Inches	14-31/32	14-31/32	14-31/32	14-31/32	14-31/32
	Width	Inches	29-17/32	29-17/32	29-17/32	39-3/8	39-3/8
	Depth	Inches	35-7/16	35-7/16	35-7/16	35-7/16	35-7/16
Net Weight	Unit	Pounds	98	100	100	111	111
Heat Exchanger			Cross Fin (Aluminum Plate Fin and Copper Tube)				
Fan	Type x Quantity		Sirocco Fan x 1	Sirocco Fan x 1	Sirocco Fan x 1	Sirocco Fan x 1	Sirocco Fan x 1
	Airflow Rate *2	CFM	353-494	353-494	477-671	547-777	636-883
	Ext. Static Pressure (208/230V)	In. W.G.	0.201-0.642/0.401-0.602-0.803				
	Motor Type		Single-phase Induction Motor				
	Motor Output	W	130	130	180	220	230
Air Filter			Optional Part				
Refrigerant Pipe Dimensions	Low Pressure	Inches	1/2 (Flare)	1/2 (Flare)	5/8 (Flare)	5/8 (Flare)	5/8 (Flare)
	High Pressure	Inches	1/4 (Flare)	1/4 (Flare)	3/8 (Flare)	3/8 (Flare)	3/8 (Flare)
Drain pipe Dimension (O.D.)		Inches	1-1/4	1-1/4	1-1/4	1-1/4	1-1/4
Sound Pressure Levels *2 (Low-High)		dB(A) @ 230V	34-39	34-39	36-41	35-41	38-43

Model Name			PEFY-P36NMHU-E	PEFY-P48NMHU-E	PEFY-P54NMHU-E	PEFY-P72NMHU-E	PEFY-P96NMHU-E
Power Source			208/230V, 1-phase, 60Hz			208/230V, 3-phase, 60Hz	
Cooling Capacity *1	Btu/h		36,000	48,000	54,000	72,000	96,000
Heating Capacity *1	Btu/h		40,000	54,000	60,000	80,000	108,000
Power Consumption	Cooling	W	683/754	683/754	695/767	1,352/1,495	1,690/1,870
	Heating	W	683/754	683/754	695/767	1,352/1,495	1,690/1,870
Current	Cooling	A	3.38/3.73	3.38/3.73	3.43/3.78	4.48/4.94	5.69/6.28
	Heating	A	3.38/3.73	3.38/3.73	3.43/3.78	4.48/4.94	5.69/6.28
External Finish			Unit: Galvanized Steel Plate				
Dimensions	Height	Inches	14-31/32	14-31/32	14-31/32	18-17/32	18-17/32
	Width	Inches	47-1/4	47-1/4	47-1/4	49-7/32	49-7/32
	Depth	Inches	35-7/16	35-7/16	35-7/16	44-1/8	44-1/8
Net Weight	Unit	Pounds	155	155	155	221	221
Heat Exchanger			Cross Fin (Aluminum Plate Fin and Copper Tube)				
Fan	Type x Quantity		Sirocco Fan x 2	Sirocco Fan x 2	Sirocco Fan x 2	Sirocco Fan x 2	Sirocco Fan x 2
	Airflow Rate *2	CFM	936-1,342	936-1,342	989-1,412	2,048	2,541
	Ext. Static Pressure (208/230V)	In. W.G.	0.201-0.642/0.401-0.602-0.803			0.28-0.642/0.40-0.80	
	Motor Type		Single-phase Induction Motor			Three-phase Induction Motor	
	Motor Output	W	400	400	400	650	850
Air Filter			Optional Part				
Refrigerant Pipe Dimensions	Low Pressure	Inches	5/8 (Flare)	5/8 (Flare)	5/8 (Flare)	3/4 (Brazed)	7/8 (Brazed)
	High Pressure	Inches	3/8 (Flare)	3/8 (Flare)	3/8 (Flare)	3/8 (Brazed)	3/8 (Brazed)
Drain pipe Dimension (O.D.)		Inches	1-1/4	1-1/4	1-1/4	1-1/4	1-1/4
Sound Levels *2 (Low-High)		dB(A) @ 230V	38-44	38-44	38-44	47	54

Note: *1 Cooling/Heating capacity indicates the maximum value at operation under the following conditions:
 Cooling: Indoor: 80°F (27°C) DB/67°F (19°C) WB; Outdoor: 95°F (35°C) DB
 Heating: Indoor: 70°F (21°C) DB; Outdoor: 47°F (8°C) DB/43°F (6°C) WB

*2 Airflow rate/sound levels are at (Low-High)

Ventilation Air: Providing sufficient ventilation air is an important part of every building design. ASHRAE standard 62 provides the minimum ventilation air requirements. Also check local codes.

Specifications are subject to change.

Effective use
of perimeter space.



Exposed Type
PFFY-P-NEMU-E



Concealed Type
PFFY-P-NRMU-E



Compact unit provides simple, effective air-conditioning in perimeter zones

Less than nine inches deep, these PFFY floor-standing units are easy to install in peripheral spaces, yet offer highly efficient air-conditioning performance. Since these are floor-standing models, they are perfect for spaces with little or no ceiling space. Their low operating sound and compact size make them ideal for hotel rooms. The PFFY offers tremendous flexibility in two distinct versions. The PFFY-NEMU exposed-type model is perfect for most applications and requires no finish work. The PFFY-NRMU is designed for applications requiring a built-in, concealed, floor-standing unit. Both types are available in six capacities: 6,000, 8,000, 12,000, 15,000, 18,000 and 24,000 Btu/h.

Optional mounting for remote controller

PFFY units can house either a Deluxe MA or ME Remote Controller in the top corner (under a cover panel). Thus, the remote controller can be mounted on the wall or in the PFFY unit.

Installation flexibility

The PFFY-P-NRMU-E unit can be field converted from top discharge to front discharge to increase installation flexibility.

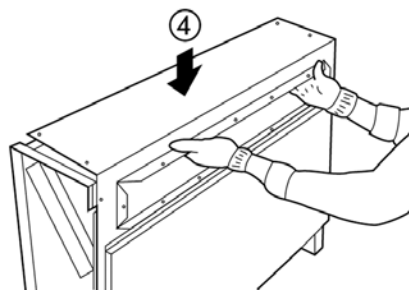
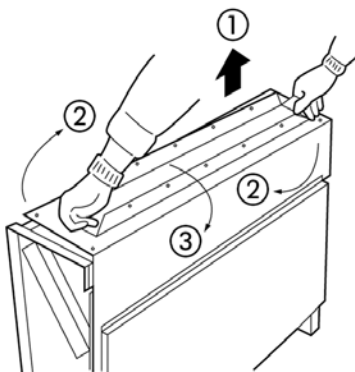

PFFY-P-NEMU/NRMU-E SPECIFICATIONS



PFFY-P-NEMU-E

Model			PFFY-P06NEMU-E	PFFY-P08NEMU-E	PFFY-P12NEMU-E	PFFY-P15NEMU-E	PFFY-P18NEMU-E	PFFY-P24NEMU-E
Power Source			208/230V, 1 Phase, 60Hz					
Cooling Capacity		Btu/h *1	6,000	8,000	12,000	15,000	18,000	24,000
Heating Capacity		Btu/h *1	6,700	9,000	13,500	17,000	20,000	27,000
Power Consumption	Cooling	W	51/61	51/61	55/67	65/78	78/93	96/114
	Heating	kW	51/61	51/61	55/67	65/78	78/93	96/114
Current	Cooling	A	0.25/0.27	0.25/0.27	0.27/0.30	0.32/0.35	0.38/0.42	0.47/0.51
	Heating	A	0.25/0.27	0.25/0.27	0.27/0.30	0.32/0.35	0.38/0.42	0.47/0.51
External Finish (Munsell No.)			Acrylic Painted (5Y 8/1)					
Dimensions	Height	Inches	24-13/16	24-13/16	24-13/16	24-13/16	24-13/16	24-13/16
	Width	Inches	41-11/32	41-11/32	46-3/32	46-3/32	55-17/32	55-17/32
	Depth	Inches	8-11/16	8-11/16	8-11/16	8-11/16	8-11/16	8-11/16
Net Weight	Unit	Pounds	51	51	56	58	67	71
Heat Exchanger			Cross Fin (Aluminum Plate Fin and Copper Tube)					
Fan	Type x Quantity		Sirocco Fan x 1	Sirocco Fan x 1	Sirocco Fan x 2	Sirocco Fan x 2	Sirocco Fan x 2	Sirocco Fan x 2
	Airflow Rate *2	CFM	194-229	194-229	247-317	300-388	353-459	353-494
	Motor Type		Single Phase Induction Motor					
	Motor Output	W	15	15	18	30	35	63
Air Filter			Standard Filter					
Refrigerant Pipe Dimensions	Low Pressure (Flare)	Inches	1/2	1/2	1/2	1/2	1/2	5/8
	High Pressure (Flare)	Inches	1/4	1/4	1/4	1/4	1/4	3/8
Drain Pipe Dimension		Inches	O.D. 1-3/32					
Sound Levels *2 (Low-High)		dB(A)	36-41	36-41	37-41	38-43	38-43	40-46

Note: *1 Cooling / Heating capacity indicates the maximum value at operation under the following conditions:
 Cooling: Indoor: 80°F (27°C) DB / 67°F (19°C) WB; Outdoor: 95°F (35°C) DB
 Heating: Indoor: 70°F (21°C) DB; Outdoor: 45°F (7°C) DB / 43°F (6°C) WB
 *2 Airflow rate/sound levels are at (Low-High)

Ventilation Air: Providing sufficient ventilation air is an important part of every building design. ASHRAE standard 62 provides the minimum ventilation air requirements. Also check local codes.

Specifications are subject to change.



PFFY-P-NRMU-E

Model			PFFY-P06NRMU-E	PFFY-P08NRMU-E	PFFY-P12NRMU-E	PFFY-P15NRMU-E	PFFY-P18NRMU-E	PFFY-P24NRMU-E
Power Source			208/230V, 1 Phase, 60Hz					
Cooling Capacity		Btu/h *1	6,000	8,000	12,000	15,000	18,000	24,000
Heating Capacity		Btu/h *1	6,700	9,000	13,500	17,000	20,000	27,000
Power Consumption	Cooling	W	51/61	51/61	55/67	65/78	78/93	96/114
	Heating	W	51/61	51/61	55/67	65/78	78/93	96/114
Current	Cooling	A	0.25/0.27	0.25/0.27	0.27/0.30	0.32/0.35	0.38/0.42	0.47/0.51
	Heating	A	0.25/0.27	0.25/0.27	0.27/0.30	0.32/0.35	0.38/0.42	0.47/0.51
External Finish (Munsell No.)			Galvanized Sheet Metal					
Dimensions	Height	Inches	25-3/16	25-3/16	25-3/16	25-3/16	25-3/16	25-3/16
	Width	Inches	34-29/32	34-29/32	39-5/8	39-5/8	49-1/16	49-1/16
	Depth	Inches	8-11/16	8-11/16	8-11/16	8-11/16	8-11/16	8-11/16
Net Weight	Unit	Pounds	41	41	45	47	56	60
Heat Exchanger			Cross Fin (Aluminum Plate Fin and Copper Tube)					
Fan	Type x Quantity		Sirocco Fan x 1	Sirocco Fan x 1	Sirocco Fan x 2	Sirocco Fan x 2	Sirocco Fan x 2	Sirocco Fan x 2
	Airflow Rate *2	CFM	194-229	194-229	247-317	300-388	353-459	353-494
	Motor Type		Single Phase Induction Motor					
	Motor Output	kW	0.015	0.015	0.018	0.030	0.035	0.063
Air Filter			Standard Filter					
Refrigerant Pipe Dimensions	Low Pressure (Flare)	Inches	1/2	1/2	1/2	1/2	1/2	5/8
	High Pressure (Flare)	Inches	1/4	1/4	1/4	1/4	1/4	3/8
Drain Pipe Dimension		Inches	O.D. 1-3/32					
Sound Levels *2 (Low-High)		dB(A)	36-41	36-41	37-41	38-43	38-43	40-46

Note: *1 Cooling / Heating capacity indicates the maximum value at operation under the following conditions:
 Cooling: Indoor: 80°F (27°C) DB / 67°F (19°C) WB; Outdoor: 95°F (35°C) DB
 Heating: Indoor: 70°F (21°C) DB; Outdoor: 45°F (7°C) DB / 43°F (6°C) WB
 *2 Airflow rate/sound levels are at (Low-High)

Ventilation Air: Providing sufficient ventilation air is an important part of every building design. ASHRAE standard 62 provides the minimum ventilation air requirements. Also check local codes.

Specifications are subject to change.

Ideal for closet
or attic applications.



The vertical air handler is ideal for installations in closets or equipment rooms where space is limited. The air handler also has a side drain pan allowing it to be installed in a horizontal left position. The vertical air handler can be connected to a system with all other CITY MULTI indoor units for complete system design flexibility.

Other features include:

- An adjustable blower static pressure from a factory set 0.30" W.G. to 0.50" W.G.
- The blower includes three fan speeds selectable at the remote controller allowing the occupant to fine tune the occupant's comfort.
- High efficiency DC Motors and a forward curved blower provide quiet efficient operation.
- A standard plug in connection allows easy integration with auxiliary heat when using the optional relay kit.
- The control board allows an easy connection for a condensate overflow safety switch.
- The cabinets are constructed of heavy gauge pre-painted steel with one inch insulation providing an R-4.2 insulating value.



*High efficiency
DC motor maintains
constant CFM even with
varying input voltages*



Vertical Airflow

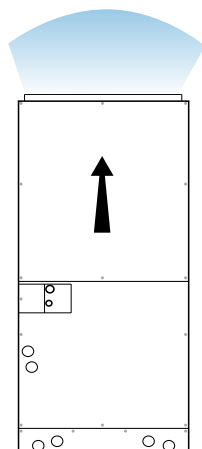

Horizontal Left Airflow

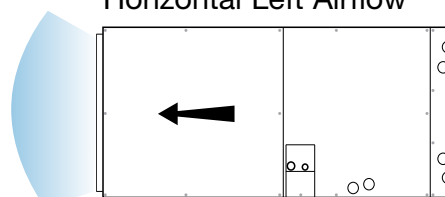

PVFY-P-E00A SPECIFICATIONS



Model Name			PVFY-P12E00A	PVFY-P18E00A	PVFY-P24E00A	PVFY-P30E00A	PVFY-P36E00A	PVFY-P48E00A	PVFY-P54E00A	
Power Source			208/230V, 1-phase, 60Hz							
Cooling Capacity		Btu/h *1	12,000	18,000	24,000	30,000	36,000	48,000	54,000	
Heating Capacity		Btu/h *1	13,500	20,000	27,000	34,000	40,000	54,000	60,000	
Power Consumption	Cooling	kW	0.17 / 0.17	0.28 / 0.28	0.26 / 0.26	0.38 / 0.38	0.32 / 0.32	0.36/0.36	0.41/0.41	
	Heating	kW	0.17 / 0.17	0.28 / 0.28	0.26 / 0.26	0.38 / 0.38	0.32 / 0.32	0.36/0.36	0.41/0.41	
Current	Cooling	A	0.69 / 0.61	1.48 / 1.31	1.48 / 1.31	2.38 / 2.11	0.93 / 1.71	2.27/2.01	2.83/2.51	
	Heating	A	0.69 / 0.61	1.48 / 1.31	1.48 / 1.31	2.38 / 2.11	0.93 / 1.71	2.27/2.01	2.83/2.51	
Dimensions	Height	Inches	42-3/4			48		58-3/4		
	Width	Inches	17-3/4			21		24-1/2		
	Depth	Inches	21					21-3/4		
Net Weight	Unit	Pounds	88	98	108	115	120	160	168	
Heat Exchanger			Aluminum Fin and Copper Tube							
Fan	Type x Qty.		Forward Curved Blower x 1							
	Airflow Rate *2	CFM	243-320-376	385-481-531	483-636-705	637-800-886	784-954-1057	982-1268-1405	1114-1426-1576	
	External Static Pressure	In. W.G.	0.30 - 0.50 (selectable)							
	Motor Type		High Efficiency DC (Single-phase Induction Motor)							
Refrigerant Pipe Dimensions	Low Pressure (Braze)	Inches	1/4	1/4	3/8	3/8	3/8	3/8	3/8	
	High Pressure (Braze)	Inches	1/2	1/2	5/8	5/8	5/8	5/8	5/8	
Drain Pipe Dimension	Primary	Inches	3/4 FPT							
	Secondary		3/4 FPT							

Note: *1 Cooling/Heating capacity indicates the maximum value at operation under the following conditions:
 Cooling: Indoor: 80°F (27°C) DB/67°F (19°C) WB; Outdoor: 95°F (35°C) DB
 Heating: Indoor: 70°F (21°C) DB; Outdoor: 47°F (8°C) DB/43°F (6°C) WB
 *2 Airflow rates are at (Low-Mid-High)

Ventilation Air: Providing sufficient ventilation air is an important part of every building design.
 ASHRAE standard 62 provides the minimum ventilation air requirements. Also check local codes.

Specifications are subject to change.

Combine with any other CITY MULTI indoor units on the same system.

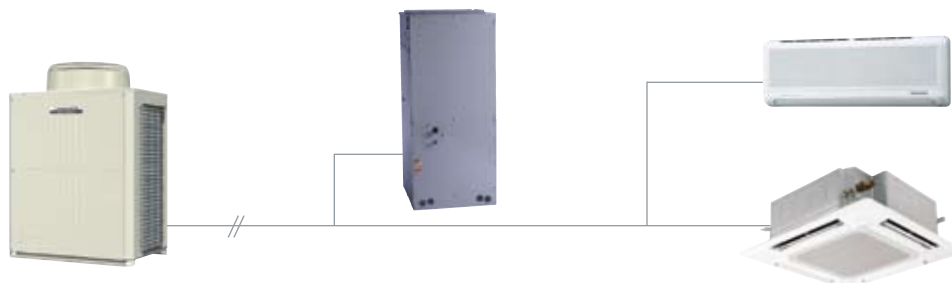

INDOOR UNITS

Our CITY MULTI Controls Network makes it easy to manage your building

The CITY MULTI Controls Network (CMCN) manages up to **2,000 indoor units** from a single networked PC in terms of operation, monitoring, scheduling (daily, weekly, and yearly), error email, personal browser, tenant billing, and maintenance diagnostic information. The CMCN puts individual, personalized comfort in the hands of the tenants and the building manager.

Flexible design for customized, individual zone control

Building owners and engineers can select from a wide variety of remote controllers and timers to satisfy the exact level of tenant control on a zone-by-zone basis, while providing the ultimate in individualized control. Each indoor unit may have one or two remote controllers or none at all.

The remote controllers allow the temperature setpoint to be changed along with On/Off control and fan speed adjustment. Mode selection (Cool/Heat/Dry/Fan/Auto) and vane control are also possible, depending on the remote controller and indoor unit.

The CMCN enables the room temperature to be sensed either at the remote controller in the zone or the temperature to be sensed at the actual indoor unit simply by changing the dip switch setting on the indoor unit. Depending on the type of the remote controller, the remote controller can be physically located in the controlled zone or in a physical location different than the controlled zone to meet the customer's specific requirements.

The versatility of the CMCN customizes each building's controls network to address the specific design and tenant requirements, while providing unparalleled comfort conditioning.

Optional easy-to-use control via PC web browser

With the CMCN, you have the option to control multiple CITY MULTI systems with the AG-150/GB-50/GB-24 Centralized Controller(s) from a PC's web browser. From Internet Explorer® on a PC, the building manager can now monitor, operate, and schedule (daily, weekly, and yearly) the HVAC system through the AG-150/GB-50/GB-24 network. Emails can be automatically generated when an abnormal condition is detected on the system with the source address and the error code. The building manager can enable tenants to control their own individual zones via a personal web browser on their networked PC in conjunction with the AG-150 or GB-50 centralized controllers.

Easy installation

It's a simple, two-pipe system with simple, non-polar, two-wire control connections. All components are daisy-chained and addressed onto the M-NET communication bus. It all adds up to less labor and materials with quicker installation.

Single-source control for up to 2,000 indoor units

From a single networked PC configured with our TG-2000 software, you can control up to 2,000 units. Our TG-2000 integrated system software provides the ultimate in building management by allowing input of the building's floor plan with illustrative icons for the CITY MULTI indoor units. This software, in conjunction with Centralized Controllers, empowers the building manager to control the HVAC system for multiple buildings in a business park, educational campus, or retirement facility.

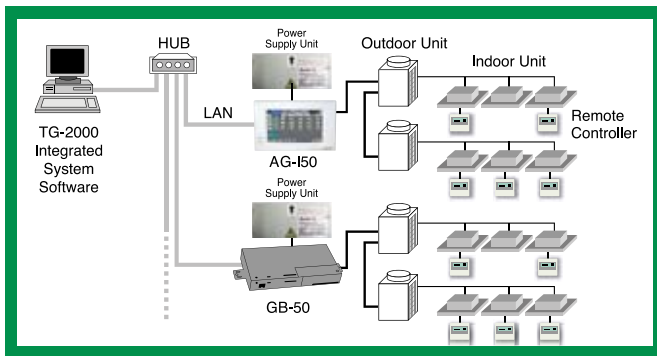

TG-2000 software manages up to 2,000 indoor units using centralized controllers and software licenses.

Tenant billing

The TG-2000 software configured with the tenant billing option and interconnected with RS-485 watt-hour meter(s) can calculate the energy consumption relative to each outdoor unit on a per-tenant basis and generate a CITY MULTI energy fee per-tenant.

System integration

Not only can our CMCN act as a stand-alone building management system, it can also integrate with existing systems via LonWorks® or BACnet® interfaces.

Model	Local remote controller				System controller										
	PAR-21MAA	PAR-F27MEA	PAC-YT51CRB	PAR-FL32MA	PAC-YT40ANRA	PAC-SF44SRA	PAC-YT34STA	AG-150 50 / 50		GB-50 50 / 50		GB-24 24 / 24		TG-2000 *4*5	
	1 / 16	1 / 16	1 / 16	1 / 16	16 / 50	50 / 50	50 / 50	AG-150	Browser*5	GB-50	Browser*4	GB-24	Browser*7	2000 / 2000	
■ Operating															
ON/OFF	○	○	○	○	◎	◎	◎	◎■	◎■	▲	◎■	▲	◎■	◎■	◎■
Mode(cool/heat/dry/fan)	○	○	○	○	N	◎	N	◎■	◎■	N	◎■	N	◎■	◎■	◎■
Temperature-set	○	○	○	○	N	◎	N	◎■	◎■	N	◎■	N	◎■	◎■	◎■
Local Permit/Prohibit	N	N	N	N	N	◎	◎	◎■	◎■	N	◎■	N	◎■	◎■	◎■
Fan speed	○	○	○	○	N	◎	N	◎■	◎■	N	◎■	N	◎■	◎■	◎■
Air-flow direction	○	○	N	○	N	◎	N	◎■	◎■	N	◎■	N	◎■	◎■	◎■
■ Status monitoring															
ON/OFF	○	○	○	○	◎	◎	◎	◎	○	▲	○	▲	○	○■	○■
Mode(cool/heat/dry/fan)	○	○	○	○	N	○	N	○	○	N	○	N	○	○	○
Temperature-set	○	○	○	○	N	○	N	○	○	N	○	N	○	○	○
Local Permit / Prohibit	○	○	○	○	○	○	○	○	○	N	○	N	○	○	○
Fan speed	○	○	○	○	N	○	N	○	○	N	○	N	○	○	○
Air-flow direction	○	○	N	○	N	○	N	○	○	N	○	N	○	○	○
Indoor temperature	○	○	N	N	N	N	N	○	○	N	○	N	○	○	○
Filter sign	○	○	N	N	N	○	N	○	○	N	○	N	○	○	○
Error flashing	○	○	○	○	○	○	○	○	○	▲	○	▲	○	○■	○■
Error code	○	○	○	N	○	○	○	○	○	N	○	N	○	○	○
Operation hour	N	N	N	N	N	N	N	N	N	N	N	N	N	●	●
■ Scheduling															
One-day	○	○	N	N	N	N	N	N	●	N	●	N	●	●	●
Times of ON/OFF per day	8	1/1	N	1/1	N	N	16	24	24	N	12	N	12	12 or 24	12 or 24
Weekly	○	N	N	N	N	N	○	○	●	N	●	N	●	●	●
Times of ON/OFF per week	8x7	N	N	N	N	N	16x7	24x7	24x7	N	12x7	N	12x7	12x7 or 24x7	12x7 or 24x7
Annual	N	N	N	N	N	N	N	N	●	N	●	N	●	●	●
Auto-off timer	○	○	N	N	N	N	N	N	N	N	N	N	N	N	N
Min. timer setting unit (minute)	1	10	N	10	N	N	5	1	1	N	1	N	1	1	1
■ Recording															
Error record	N	N	N	N	N	○	N	○	○	N	○	N	○	○	○
Daily/monthly report	N	N	N	N	N	N	N	N	N	N	N	N	N	◎	◎
Electricity charge	N	N	N	N	N	N	N	N	N	N	N	N	N	●	●
■ Other															
Temperature-set limitation	○*6	○	○*6	N	N	△	N	N	○*2	N	○*2	N	○*2	○	○
Auto-lock	○	○	N	N	N	N	N	N	N	N	N	N	N	N	N
■ Management (Group/Interlocked)															
Ventilation interlock	N/O	N/O	N/O	N	○	○	○	○	○/○*2	N	○/○*2	N	○/○*2	○/○	○/○
Group setting	○*1	○	○*1	N	○	○	○	○	○*2	N	○*2	N	○*2	○	○
Block setting	N	N	N	N	N	N	N	○	○*2	N	○*2	N	○*2	○	○
Revision of electricity charge	N	N	N	N	N	N	N	N	N	N	N	N	N	□●	□●
■ Operating on LOSSNAY interlocked (Group/Interlocked)															
ON/OFF	N/O	N/O	N/O	N/O	◎/◎*3	◎/◎	◎/◎	◎/◎	◎/◎	▲/▲	◎/◎	▲/▲	◎/◎	◎/◎	◎/◎
Fan speed	N/O	N/O	N	N	N	◎/◎	N	◎/◎	◎/◎	N/N	◎/◎	N/N	◎/◎	◎/◎	◎/◎
Ventilation mode	N/N	N	N	N	N	◎/N	N	◎/N	◎/N	N/N	◎/N	N/N	◎/N	◎/N	◎/N
■ Status monitoring on LOSSNAY interlocked (Group/Interlocked)															
ON/OFF	N/O	N/O	N	N	N	○/○	○/○	◎/◎	◎/◎	▲/▲	◎/◎	▲/▲	◎/◎	◎/◎	◎/◎
Fan speed	N/O	N/O	N	N	N	○/○	N	○/○	○/○	N/N	○/○	N/N	○/○	○/○	○/○
Ventilation mode	N	N	N	N	N	○/N	N	○/N	○/N	N/N	○/N	N/N	○/N	○/N	○/N

- ◎ : Each group / Batched; ○ : Each group; □ : Block (for CITY MULTI Indoor unit, not for all Mr.SLIM);
- : GB-50/AG-150 license registration possible. N : Not Available (Not Used.) △ : Batched only;
- ▲ : Batched handling (for maintenance) ■ : Block

*1. Group setting via wiring between Indoor units with cross-over cable;
 *2. Installation possible at Initial setting web browser;
 *3. Inter-lock is set at Local remote controller.
 *4. GB-50 license registration to GB-50 is required to monitor and operate the units by browser and TG-2000.
 *5. AG-150 license registration to AG-150 is required to monitor and operate the units by browser and TG-2000.
 *6. This function can be set only on the remote controller. This function cannot be used with the System controller (AG150, GB-50/GB-24, TG-2000, and PAC-SF44SRA).
 *7. **GB-24 license registration is required to monitor and operate the units by browser and TG-2000.**

CENTRALIZED CONTROLLER AG-150



Option: Black surface cover.
PAC-YG71CBL

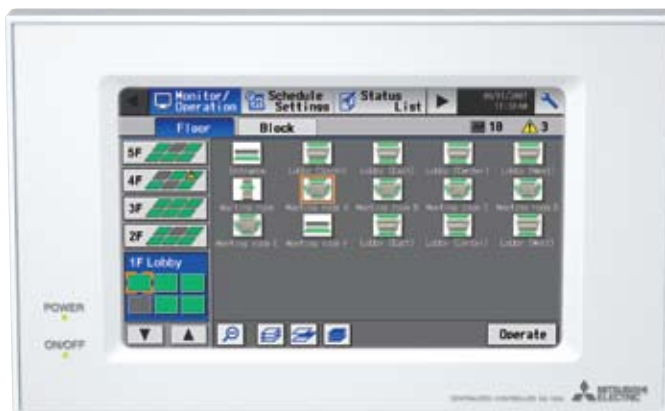

Function	Description
Touch Screen	9" high resolution color touch screen
Max No. of Indoor Units	Up to 50 indoor units can be connected
ON/OFF	On/Off operation for a single group and batch operation
Operation Mode	Cool/Dry/Auto/Fan/ Heat Auto mode is available with only R2 and WR2 systems
Temperature Setting	Sets the temperature for a single group. <ul style="list-style-type: none"> Cool/Dry: 67-87° F (57-87° F) / 19-30°C (14-30° C) Heat: 63-83° F (63-83° F) / 17-28° C (17-28° C) Auto: 63-83° F (63-83° F) / 19-28° C (17-28° C) (For PDFY/PEFY/PFFY by setting Dip SW 1-7 to ON and limits to HIGH fan speed only)
Fan Speed Setting	Models with 4-airflow speed settings: Hi/Mid-2/Mid-1/Low Models with 3-airflow speed settings: Hi/Mid/Low Models with 2-airflow speed settings: Hi/Low
Air Flow Direction Setting	Air flow angles: 100° - 80° - 60° - 40° and swing Air flow direction settings vary depending on indoor unit model
Permit/Prohibit Function	Individual prohibit operations for each remote controller function (ON/OFF, Set Temperature, Operation Mode and Filter reset)
Indoor Return Air Temperature	Displays the measured return air temperature from each group
Error Indication	Displays a 4 digit code and the affected unit address
Test Run Function	Allows indoor units to operate in test mode
Ventilation Interlock	Allows the group to be interlocked with Lossnay unit
Schedule Operation	Weekly schedule can be set by groups based on operation pattern
External Input/Output	Inputs: Level Signal-Batch Start/Stop, Batch Emergency Stop Outputs: Start/Stop Status, Error/Normal Status
Power Supply	PAC-SC51KUA
Dimensions - (W x D x H)	11-13/16" x 2-7/16" x 6-7/8"

AG-150 Software Options *(details on optional software on page 53)*

SW-Mon	PC monitoring
SW-Sch	PC scheduling
SW-Email	Error email
SW-Maint	Online Maintenance Tool
SW-Charge	Tenant billing (requires TG-2000)
SW-Pweb	Personal web browser
SW-BACnet	BACnet® interface

Available Spring 2009



Function	Description
Max No. of Indoor Units	Up to 50 indoor units can be connected
ON/OFF	On/Off operation for a single group and batch operation
Operation Mode	Cool/Dry/Auto/Fan/ Heat. Auto mode is available with only R2 and WR2 systems
Temperature Setting	Sets the temperature for a single group. <ul style="list-style-type: none"> Cool/Dry: 67-87° F (57-87° F) / 19-30° C (14-30° C) Heat: 63-83° F (63-83° F) / 17-28° C (17-28° C) Auto: 63-83° F (63-83° F) / 19-28° C (17-28° C) (For PDFY/PEFY/PPFY by setting Dip SW 1-7 to ON and limits to HIGH fan speed only)
Fan Speed Setting	Models with 4-airflow speed settings: Hi/Mid-2/Mid-1/Low Models with 3-airflow speed settings: Hi/Mid/Low Models with 2-airflow speed settings: Hi/Low
Air Flow Direction Setting	Air flow angles: 100° - 80° - 60° - 40° and swing Air flow direction settings vary depending on indoor unit model
Permit/Prohibit Function	Individual prohibit operations for each remote controller function (ON/OFF, Set Temperature, Operation Mode and Filter reset)
Indoor Return Air Temperature	Displays the measured return air temperature from each group
Error Indication	Displays a 4 digit code and the affected unit address
Ventilation Interlock	Allows the group to be interlocked with Lossnay unit
Schedule Operation	Weekly schedule can be set by groups based on operation pattern *requires PC Monitoring (SW-Mon) and PC Scheduling (SW-Sch)
External Input/Output	Inputs: Level Signal-Batch Start/Stop, Batch Emergency Stop Outputs: Start/Stop Status, Error/Normal Status
Power Supply	PAC-SC51KUA or PAC-SC50KUA
Dimensions - (W x D x H)	9-7/8" x 1-1/2" x 5-1/8"

GB-50 Software Options (details on optional software on page 53)

SW-Mon	PC monitoring
SW-Sch	PC scheduling
SW-Email	Error email
SW-Maint	Online Maintenance Tool
SW-Charge	Tennant billing (requires TG-2000 software)
SW-Pweb	Personal web browser
SW-BACnet	BACnet® interface



Function	Description
Max No. of Indoor Units	Up to 24 indoor units can be connected
ON/OFF	On/Off operation for a single group and batch operation
Operation Mode	Cool/Dry/Auto/Fan/ Heat. Auto mode is available with only R2 and WR2 systems
Temperature Setting	Sets the temperature for a single group. <ul style="list-style-type: none"> Cool/Dry: 67-87° F (57-87° F) / 19-30oC (14-30° C) Heat: 63-83° F (63-83° F) / 17-28° C (17-28° C) Auto: 63-83° F (63-83° F) / 19-28° C (17-28° C) <small>(For PDFY/PEFY/PFFY by setting Dip SW 1-7 to ON and limits to HIGH fan speed only)</small>
Fan Speed Setting	Models with 4-airflow speed settings: Hi/Mid-2/Mid-1/Low Models with 3-airflow speed settings: Hi/Mid/Low Models with 2-airflow speed settings: Hi/Low
Air Flow Direction Setting	Air flow angles: 100° - 80° - 60° - 40° and swing Air flow direction settings vary depending on indoor unit model
Permit/Prohibit Function	Individual prohibit operations for each remote controller function (ON/OFF, Set Temperature, Operation Mode and Filter reset)
Indoor Return Air Temperature	Displays the measured return air temperature from each group
Error Indication	Displays a 4 digit code and the affected unit address
Ventilation Interlock	Allows the group to be interlocked with Lossnay unit
Schedule Operation	Weekly schedule can be set by groups based on operation pattern <small>*requires PC Monitoring (SW-Mon) and PC Scheduling (SW-Sch)</small>
External Input/Output	Inputs: Level Signal-Batch Start/Stop, Batch Emergency Stop Outputs: Start/Stop Status, Error/Normal Status
Power Supply	PAC-SC51KUA or PAC-SC50KUA
Dimensions - (W x D x H)	9-7/8" x 1-1/2" x 5-1/8"

GB-24 Software Options (details on optional software on page 53)

SW-Mon	PC monitoring
SW-Sch	PC scheduling
SW-Email	Error email
SW-Maint	Online Maintenance Tool

The Centralized Controllers support operations that supersede control of the remote controllers and include system configuration, daily/weekly scheduling, operation, and malfunction monitoring. All Centralized Controllers are equipped with an RJ-45 Ethernet port to support interconnection with a networked PC via a closed/direct Local Area Network (LAN). Software functions are available so that the building manager can securely log into each Centralized Controller via the PC's web browser to support operation monitoring, daily/weekly/yearly scheduling, error email distribution, personal browser, and maintenance diagnostics.

Software functions for the PC include web monitoring, web scheduling, error email, personal browser, online maintenance tool tenant billing (requires TG-2000 on dedicated PC) and BACnet (requires dedicated PC). The optional software functions are licensed per Centralized Controller.

PC monitoring (SW-Mon)

This feature enables the building manager to easily monitor and operate all 50 units from the PC's browser.

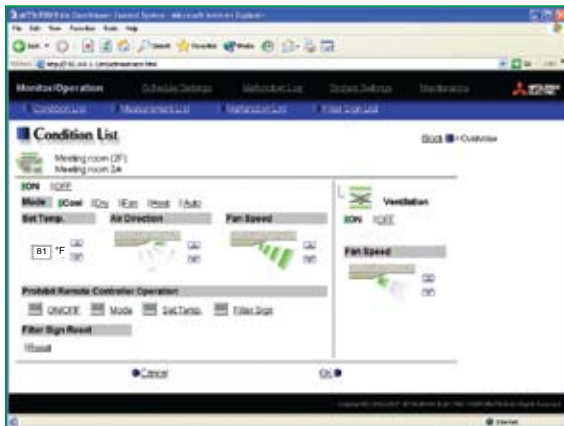

PC scheduling (SW-Sch)

This function enables the building manager to customize daily, weekly, and yearly schedules for all 50 units. Schedules can be applied to a single unit, a group of units, or collectively (batch) to all units.



Error email (SW-Email)

If an error occurs on the CITY MULTI system monitored by the Centralized Controller, the fault will be detected and isolated, and a detailed alert will be sent to the necessary personnel via real-time email. The user can then view and clear the error logs from the PC and use the information for troubleshooting.

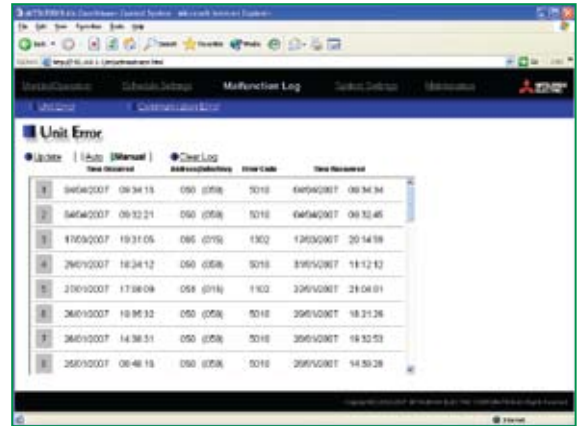

Online maintenance tool (SW-Maint)

This capability performs maintenance diagnostics via a network PC, the Centralized Controller and Maintenance Tool software (see page 60 for more details on Maintenance Tool software).

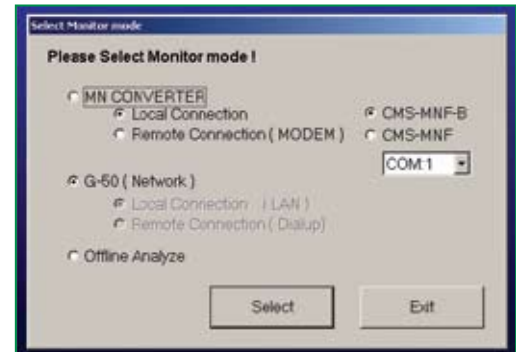

Individual personal browser via PC web browser (SW-Pweb)

This innovation allows individual users to control their zone conditioning via a personal networked PC with or without a remote controller. Personal web browser is only supported on AG-150 and GB-50 Centralized Controllers.

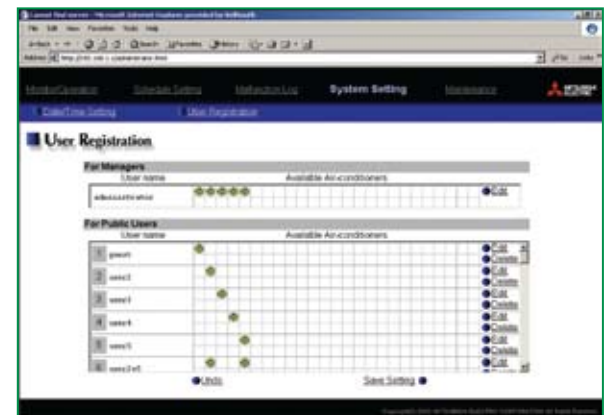

Deluxe MA Remote Controller (PAR-21MAA)

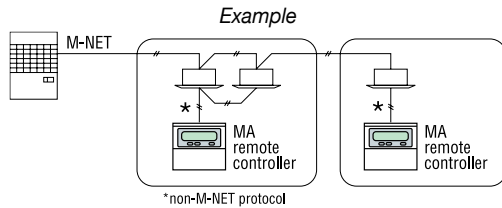

- Features user-friendly multilingual operation and monitoring.
- Controls up to 16 indoor units in a single group.
- User Functions: Allows user to set:
 - On/Off
 - operation modes of Cool, Heat, Dry, Fan, or Auto (R2-Series only), ventilation
 - set temperature from 57° F – 87° F, depending on operation mode and indoor unit.
 - fan speed setting
 - airflow direction
- Timer Operation: Supports Weekly Timer operation (On/Off/Set Temperature). Supports Auto-Off Timer.
- Room Temperature: Displays room temperature sensed either at the Remote Controller or at the indoor unit.
- Set Temperature Range Limit: Reduces the allowable set temperature range in Cool or Heat modes from Remote Controller.
- Function Lock Out: Prohibits all functions or all functions except On/Off.
- Diagnostics: Displays four-digit error code.
- Grouping: Can only be used in same group with other PAR-21MAA Deluxe MA Remote Controllers and PAC-YT51 Simple MA remote controllers, with up to two remote controllers per group.
- Addressing: No addressing required.
- Wiring: Connects using two-wire, stranded, non-polar control wire to TB15 connection terminal on the indoor unit. Requires cross-over wiring for grouping across indoor units.
- Dimensions: 5-1/8" x 3/4" x 4-3/4"

ME Remote Controller (PAR-F27MEA)

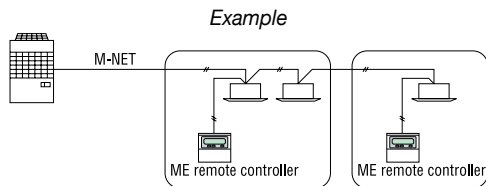

- Features user-friendly operation and monitoring.
- Controls up to 16 indoor units in a single group.
- User Functions: Allows user to set:
 - On/Off
 - operation modes of Cool, Heat, Dry, Fan, or Auto (R2-Series only), ventilation
 - set temperature from 57° F – 87° F, depending on operation mode and indoor unit.
 - fan speed setting
 - airflow direction
- Timer Operation: Supports repeated daily timer operation of one On/Off setting repeated every day and an Auto-off timer.
- Room Temperature: Displays room temperature sensed either at the Remote Controller or at the indoor unit.
- Set Temperature Range Limit: Reduces the allowable set temperature range in Cool or Heat modes from Remote Controller or PC.
- Function Lock-Out: Prohibits all functions or all functions except On/Off.
- Diagnostics: Displays four-digit error code and error unit address.
- Grouping: Can be used only in same group with a total of two PAR-F27MEA (ME Remote Controllers) per group.
- Addressing: Requires manual addressing using rotary dial switch to the M-NET communication bus.
- Wiring: Connects using two stranded, non-polar control wires to TB5 connection terminal on the indoor unit.
- Dimensions: 5-1/8" x 3/4" x 4-3/4"

Simple MA Remote Controller (PAC-YT51CRB)



- Features user-friendly operation and monitoring.
- Controls up to 16 indoor units in a single group.
- User Functions: Allows user to set:
 - On/Off
 - operation modes of Cool, Heat, Dry, Fan, Auto (R2-Series only), Ventilation
 - fan speed setting
 - set temperature from 57° F – 87° F, depending on operation mode and indoor unit.
- Grouping: Can be used only in same group with other PAC-YT51 (Simple MA Remote Controller) and PAR-21MAA (Deluxe MA Remote Controller) with up to two remote controllers per group.
- Addressing: No addressing required.
- Set Temperature Range Limit: Reduces the allowable set temperature range in Cool or Heat modes from Remote Controller.
- Diagnostics: Displays four-digit error code and error unit address.
- Wiring: Connects using two stranded, non-polar control wires to TB15 connection terminal on the indoor unit. Requires crossover wiring for grouping across indoor units.
- Dimensions: 2-3/4" x 1-5/8" x 4-3/4"

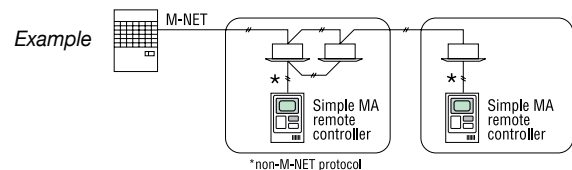

Wireless MA Remote Controller (PAR-FL32MA) and Receiver (PAR-FA32MA)



- Features user-friendly operation and monitoring.
- Controls up to 16 indoor units in a single group.
- User Function: Allows user to set:
 - On/Off
 - operation modes of Cool, Heat, Dry, Fan or Auto (R2-Series only)
 - set temperature from 57° F – 87° F, depending on operation mode and indoor unit.
 - fan speed setting
 - airflow direction
- Grouping: Can be used only in same group with PAC-YT51 (Simple MA Remote Controller), PAR-21MAA (Deluxe MA Remote Controller), and other PAR-FL32MA (Wireless MA Remote Controllers).
- Addressing: No addressing required.
- Wiring: Connects using two stranded, non-polar control wires to TB15 connection terminal on the indoor unit. Requires crossover wiring for grouping across indoor units.
- Dimensions: Remote (2-5/16" x 3/4" x 5-1/4"), Receiver (2-3/4" x 7/8" x 4-12/16")

(Receiver (PAR-FA32MA) not shown)

On/Off Controller (PAC-YT40ANRA)



- On/Off Control for up to 16 Groups (max. of 50 indoor units).
- Collective On/Off Button turns all units on/off. Collective LED displays if any units are on, off, or in error.
- Individual On/Off Button for 16 groups of indoor units. Turns individual group on/off. Individual LED displays if any units in the group are on, off, or in error.
- Diagnostics: Flashing LED indicates error. Displays four-digit error code.
- Addressing: Requires manual addressing using rotary dial switch to the M-NET communication bus (default address is 201).
- Wiring: Connects to TB7 connection terminal on outdoor unit via PAC-SC50KUA power supply or connects to TB3 connection terminal on outdoor unit.
- Dimensions: 5-1/8" x 3/4" x 4-3/4"
- Recommended to be used in conjunction with PAR-21MAA Deluxe MA Remote Controllers or PAR-F27MEA ME Remote Controllers for temperature and mode setting.
- Expandability: External input signal can be used for batch operation such as Emergency Stop, On/Off, or On/Off plus prohibit of local remote controller operation. External output signal for collective operation state or error state.

Schedule Timer (PAC-YT34STA)



- Schedules up to 50 indoor units. Maximum number of indoor units per one group is 16. Maximum number of groups is 50.
- Use only in conjunction with PAR-21MAA (Deluxe MA Remote Controllers) or PAR-F27MEA (ME Remote Controllers).
- Scheduling: Supports up to nine patterns with up to 16 operations per pattern. Operations include On/Off, mode selection (Cool, Heat), set temperature, and prohibition of remote controller functions (On/Off, operation mode change, and set temperature adjustment). Patterns are applied to each group of indoor units on a per-day basis. Minimum time interval is five minutes.
- Diagnostics: Displays four-digit error code and error unit address.
- Addressing: Requires manual addressing using rotary dial switch to the M-NET communication bus.
- Wiring: Connects to TB7 connection terminal on outdoor unit with the PAC-SC50KUA power supply or connects to TB3 connection terminal on outdoor unit.
- Dimensions: 5-1/8" x 3/4" x 4-3/4"
- Expandability: Can be used in conjunction with G-50A Centralized Controller, which has higher priority but requires change in dip-switch setting. Can be used in conjunction with external input/output signals.

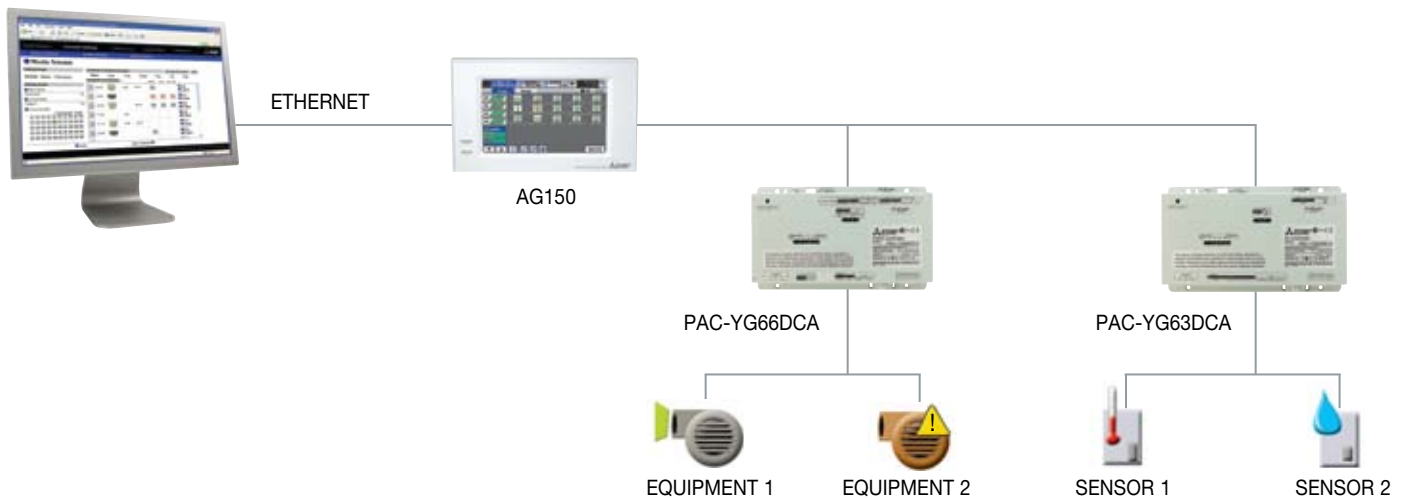

PAC-YG66DCA Digital Input Digital Output (DIDO) Control Board

The DIDO controller used in conjunction with a AG-150, GB-50, or GB-24 Centralized Controller can control and monitor third party general equipment.

Function	Description
Inputs	Qty 2 digital inputs (non-voltage contacts)
Outputs	Qty 2 digital outputs (non-voltage relay contact) Use only VDC with outputs
Monitor	Status, Fault Requires AG-150, GB-50, or GB-24 Centralized Controller
Control	On/Off, Start/Stop, Enable/Disable Requires AG-150, GB-50, or GB-24 Centralized Controller
Schedule Operation	Weekly schedule can be set by groups based on operation pattern Requires AG-150, GB-50, or GB-24 Centralized Controller
Interlock Function	Interlock M-NET devices and output contacts according to status of input contacts
Power Supply	24 VDC (5W plus loads)
Communication	M-NET
Dimensions - (W x D x H)	7-7/8" x 1-13/16" x 4-3/4"

PAC-YG63MCA Analog Input (AI) Control Board

The AI controller used in conjunction with a AG-150, GB-50, or GB-24 Centralized Controller can monitor and trend temperature and humidity from a field supplied temperature or humidity sensor.

Function	Description
Inputs	Qty 2 digital inputs (0/10 VDC, 4/20 mA, 1-5 VDC)
Monitor	Temperature and/or Humidity Requires AG-150, GB-50, or GB-24 Centralized Controller and field supplied sensor
Interlock Function	Interlock M-NET devices and output contacts according to measured values on inputs
Alarms	Generate alarm based on user defined high and low limits
Power Supply	24 VDC (5W)
Communication	M-NET
Dimensions - (W x D x H)	7-7/8" x 1-13/16" x 4-3/4"

The TG-2000 integrated system software enables the user to control multiple AG-150/GB-50/GB-24 controllers and provide enhanced functions from a single, dedicated networked PC configured with the TG-2000 software and AG-150/GB-50/GB-24 software licenses. The TG-2000 configured PC is capable of controlling up to 2,000 indoor units with the AG-150/GB-50/GB-24 Centralized Controllers.

Additional software features are available through the TG-2000 software including tenant billing.

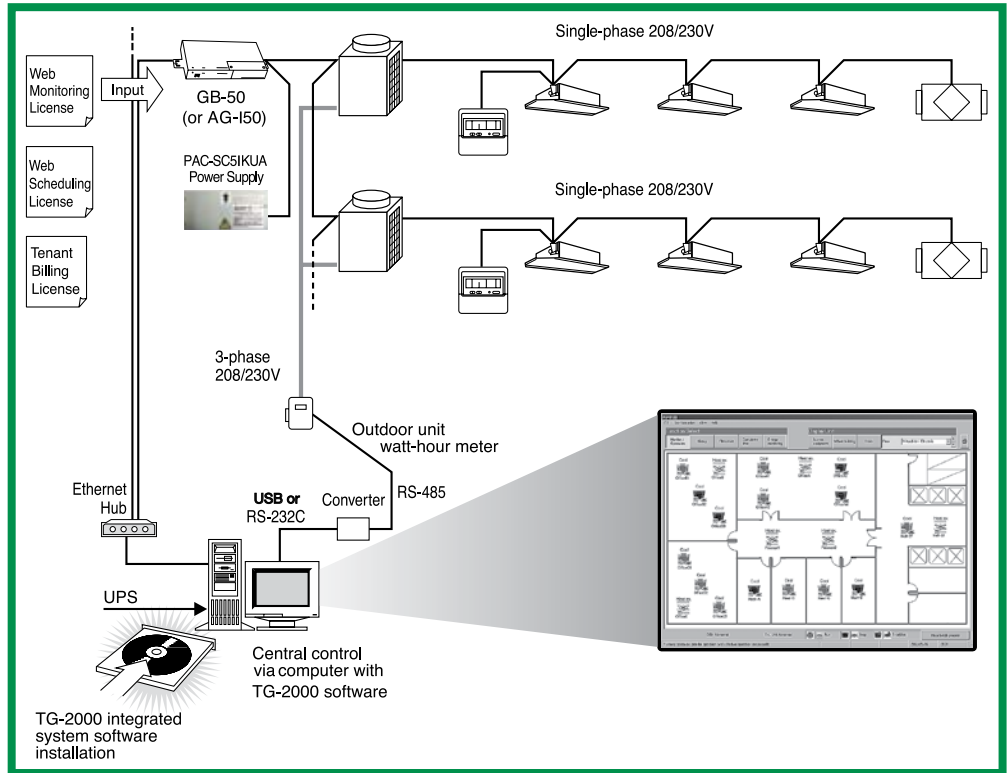

Tenant billing (requires AG-150, GB-50 or G-50)

The tenant billing function of TG-2000 will output the HVAC energy consumption fee in kWh and monetary amount for the CITY MULTI outdoor unit(s) divided among defined blocks of indoor units. The tenant billing function requires that a RS-485 WHM monitor the energy consumption of one or more CITY MULTI outdoor units and be intercon-

nected to the TG-2000 computer via a RS-485/RS-232C or RSC485/USB converter. The tenant billing output can be sent directly to a networked printer and/or to a destination folder on the TG-2000 PC as an Excel® file. This tenant billing output can then be input into an Excel-based support tool to generate an individual HVAC Energy Fee per tenant. The format of this HVAC Energy Fee can be customized.

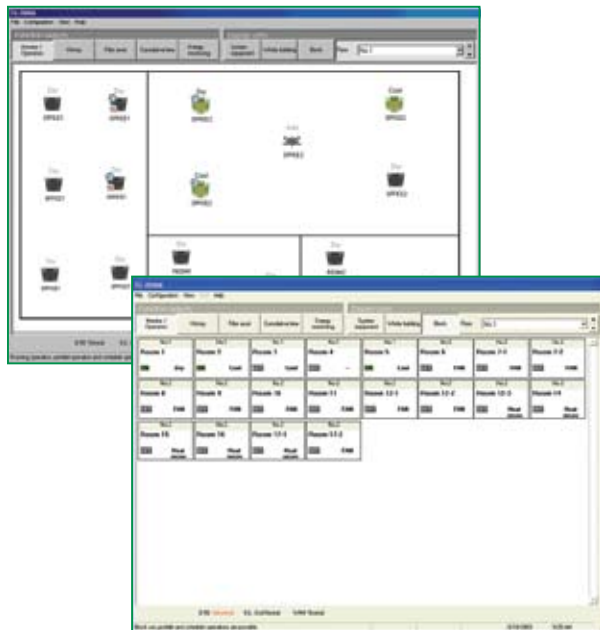

The CMCN supports integration with Building Management Systems (BMS) via our LonWorks® and BACnet® interfaces.

LonWorks®

The Mitsubishi Electric HVAC LonWorks® interface, LMAP03U, supports up to 50 indoor units with a variety of network variables on a per indoor unit basis. Input variables include, but are not limited to, On/Off, Operation Mode, Fan Speed, Prohibit Remote Controller, and Filter Sign Reset. Output variables include but are not limited to Model Size, Alarm State, Error Code, and Error Address.

BACnet®

The Mitsubishi Electric HVAC BACnet interface, (SW-BACnet), is compliant with BACnet/IP (ANSI/ASHRAE 135-1995, 135a) and UDP/IP of Ethernet (ANSI/ASHRAE 135-1995, 135b). Our BACnet interface requires a dedicated networked computer configured with the BACnet interface software and the BACnet software license per AG-150/GB-50, licensed by Mitsubishi Electric HVAC. A maximum of 10 AG-150/GB-50 Centralized Controllers are supported via the BACnet PC for a maximum of 500 indoor units for BACnet integrations.

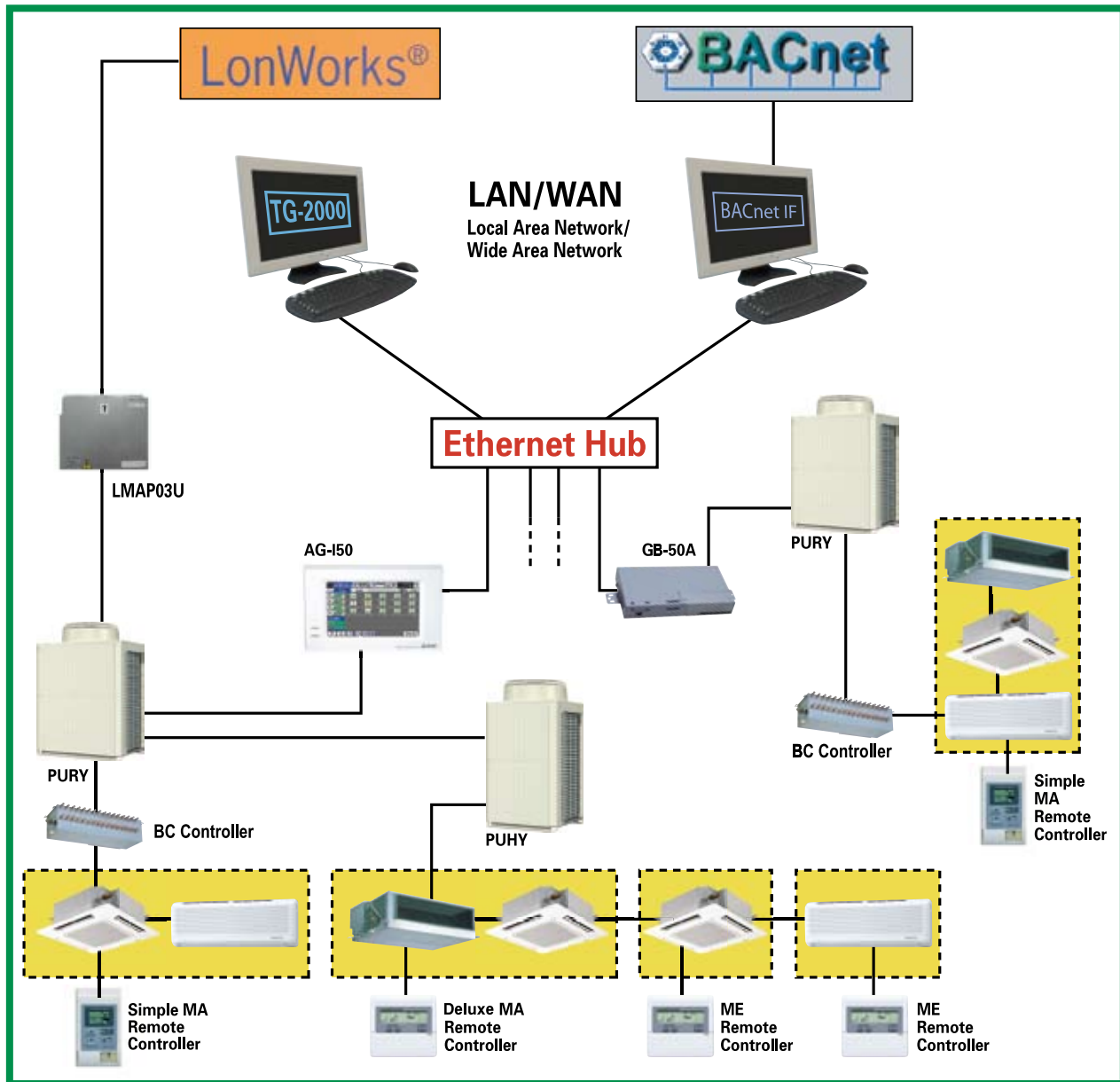

Lossnay energy recovery ventilators provide **outdoor air solutions** for indoor environmental quality.



See the Lossnay Technical Brochure for complete information.



Model	CFM	Model	CFM
LGH-F300RX3-E	300	LGH-F470RX3-E	470
LGH-F600RX3-E	600	LGH-F1200RX3-E	1,200

Improved sound attenuation makes Lossnay® units quiet enough for places where silence is a must, such as meeting rooms and libraries. A free-cooling function is standard to help reduce costs and boost efficiency. The integrated, bypass damper design makes installation and system management quick and efficient.

Interlock simply, effectively, and economically

Because the M-NET adapter comes as standard equipment, networking systems connected with Mitsubishi Electric air conditioners has never been easier. There is no need to purchase additional parts. Systems can be assembled simply and logically, reducing construction times and keeping initial costs low.

Bypass auto ventilation standard

Lossnay models offer three ventilation modes:

- Energy Recovery - Heat Exchange
- Bypass - No Exchange
- Automatic - Heat Exchange/Bypass

With conventional ERVs, bypass ventilation was impossible without attaching additional dampers and adapters. With the LGH-F-RX3-E series, however, this mode is available without the use of other parts. Additionally, automatic mode allows the system to select recovery or bypass as required. Mode selection is easy when interlocked with M-NET systems using the PZ-52SF remote controller, which is sold separately. When using Lossnay independently, the separately sold PZ-41SLB remote controller provides mode selection.

System compatibility

The LGH-F-RX3-E series is fully compatible with Mitsubishi Electric's TG-2000 software, LMAP LonWorks® interface and BACnet® interface, further increasing the scope of total system management.

Multi-function LCD remote controller

These ERV remote controllers are compact and attractive. In addition to controls for ON/OFF, Run mode, and Ventilation mode, the time period for filter maintenance is also displayed. The liquid crystal display has been designed for easier visibility. The Lossnay M-NET controller, model PZ-52SF-E, can control up to 16 Lossnay units in a single group.

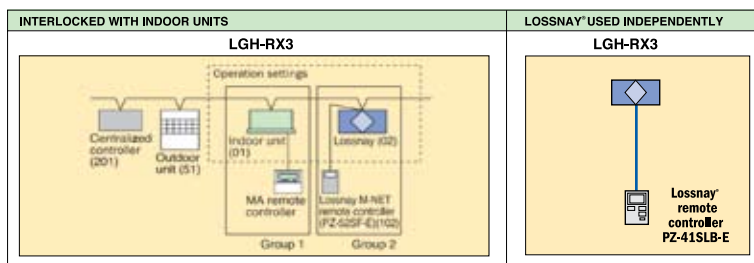

Mitsubishi Electric has responded to the growing need for total, integrated management of building HVAC and indoor air quality by making it easier to interlock and control Lossnay® energy recovery ventilators with our air-conditioning systems.

Maintenance Tool Overview



Mitsubishi's easy-to-use, Windows® based Maintenance Tool software allows technicians to monitor and collect CITY MULTI system data and control various functions of the system for maintenance purposes. System monitoring is accomplished through direct connection between your PC and the M-NET bus line using the MN-Converter or by connecting remotely to a system centralized controller such as the AG-150 or GB-50 via a TCP/IP network, or via a remote dialup connection.

Use Maintenance Tool software to monitor pressure and temperature readings from CITY MULTI system sensors, display and control system LEV settings and display and remotely control all connected indoor units.

Maintenance Tool software also allows the technician to record and save system monitor data for the purposes of trending and system analysis off site as well as display malfunction logs and email error reports to personnel responsible for servicing the system.



MN Converter (CMS-MNG-E)



The mode select screen allows the user to select the method for connection to the CITY MULTI system whether direct or remotely or choose to analyze previously recorded data off-line.

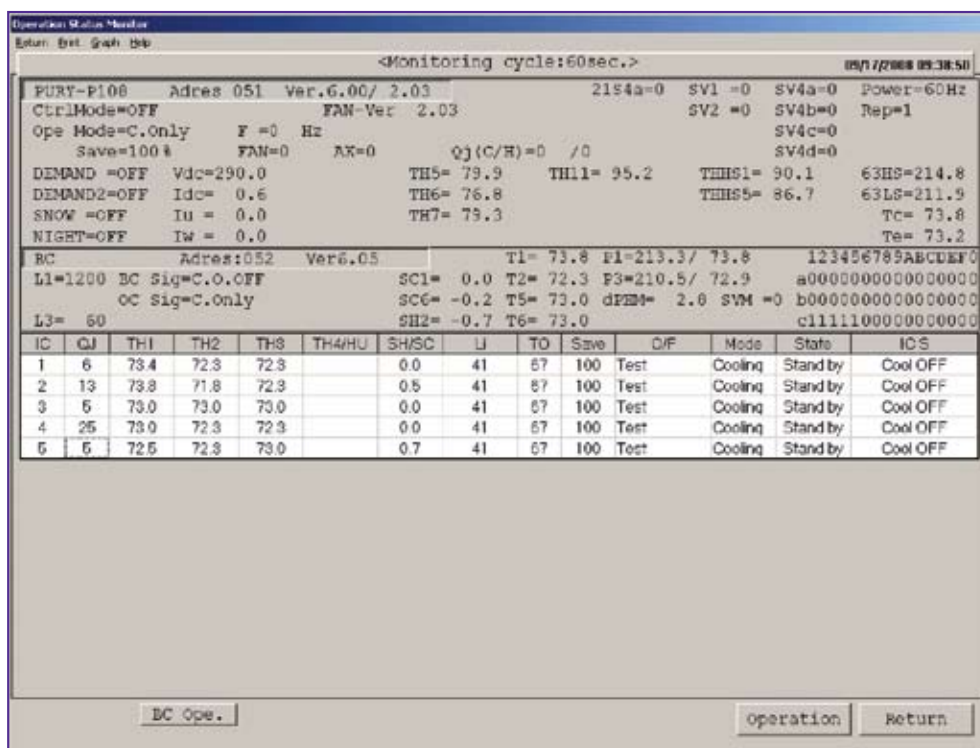

The operation status monitor screen displays the operational data for the connected system including system pressures, temperatures, LEV settings, compressor frequency, current operational mode, and more. Pre-recorded data can also be viewed in and off-line version of this screen.

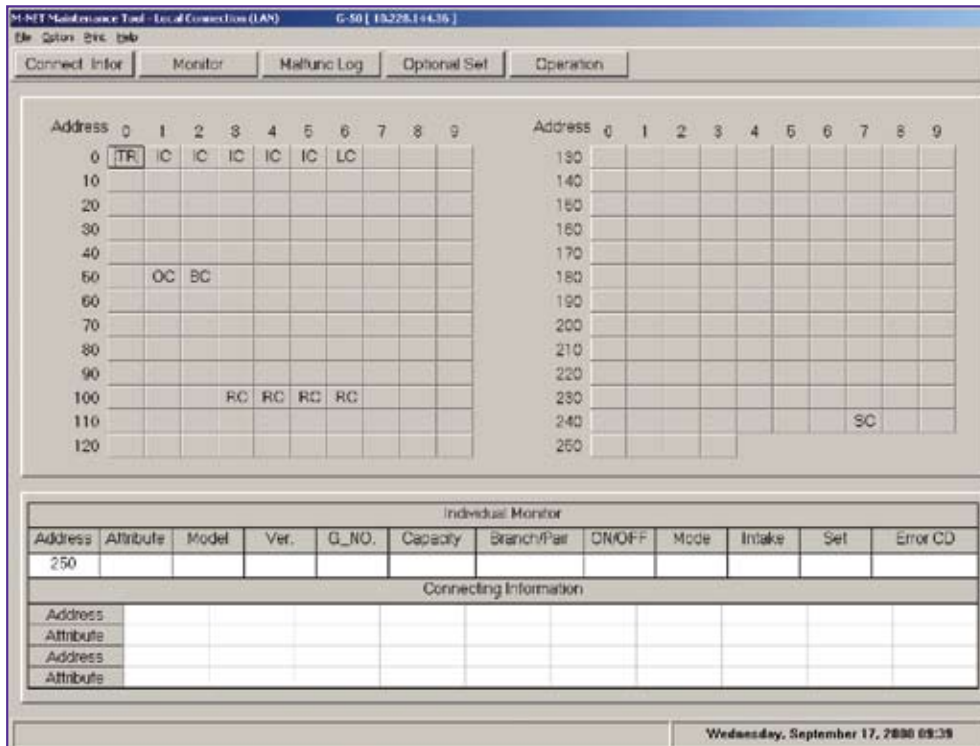

The system connection information view shows a snapshot of the components connected to the system, identifying each component's type and system address. Through a simple series of clicks, the user can monitor the critical data points for each component, manipulate the control features and operate each component, or view each component's malfunction log.

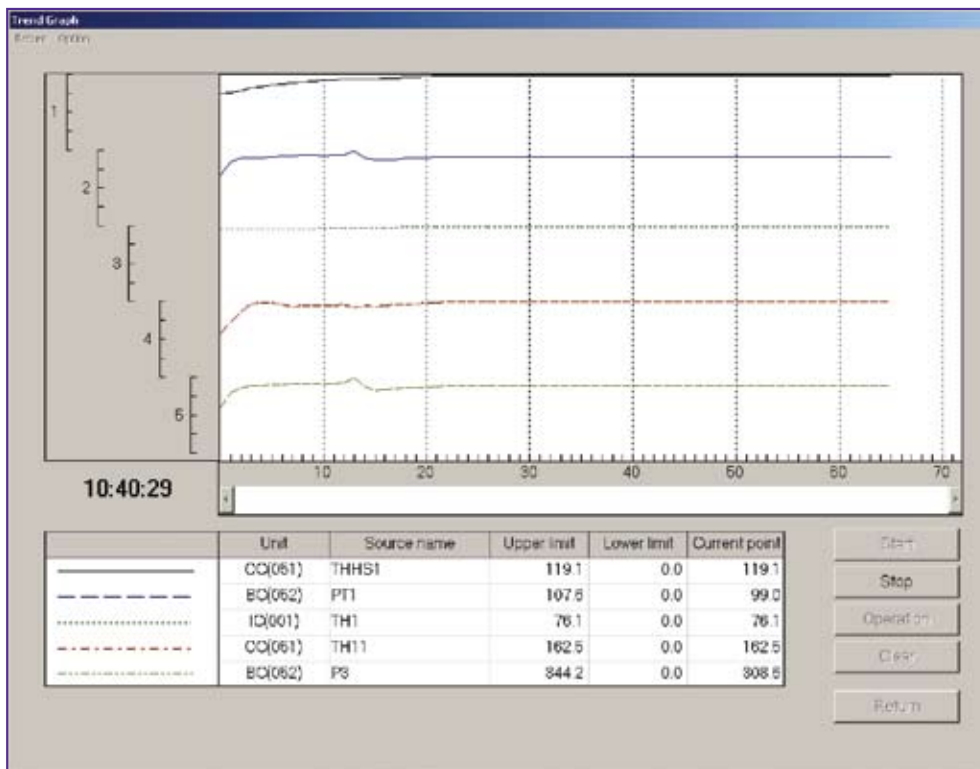

Maintenance Tool allows the user to identify and select specific points to monitor and graph over time for the purposes of data trending and system diagnostics.

Design Tool Software Overview

Mitsubishi's Design Tool software makes designing with CITY MULTI quick and easy. The designer just needs to drag and drop components to complete the design. The program has built in safeguards against exceeding limitations and shows if there is an error. Assuring line lengths, maximum connected capacities, component selection, control scheme, etc. are within the system requirements.

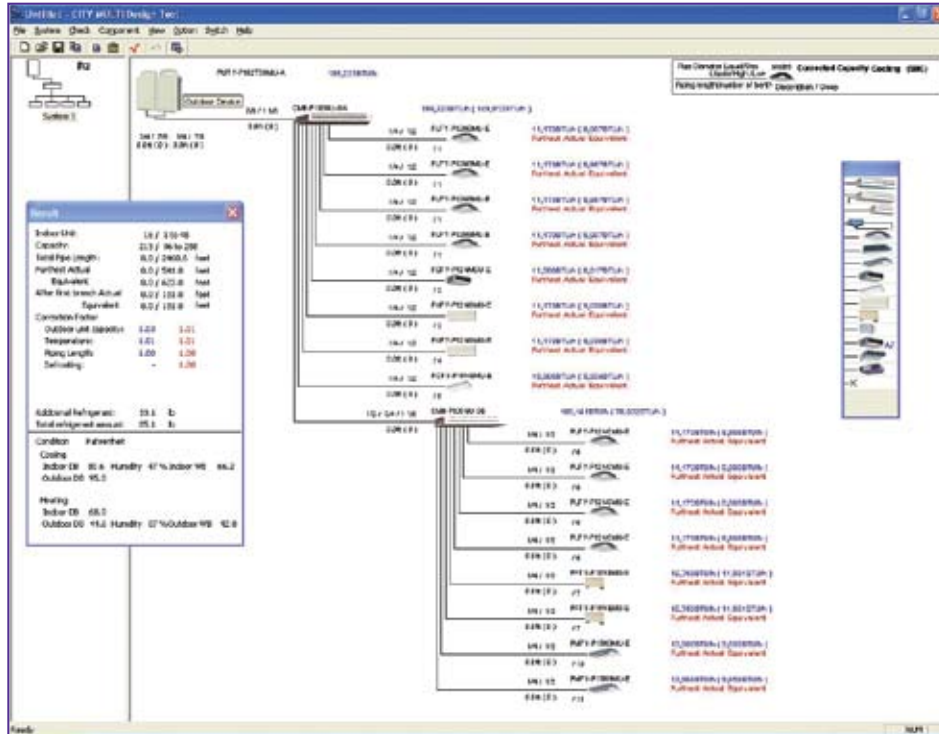

Project Property	
Prepared on:	09/19/2008
Customer's name:	Burnsby University
Comment:	Admissions Building
Frequency:	60Hz
Refrigerant:	R410A
Region:	FIELD (U.S.)
Design Condition	
Area: Testing condition	
Outdoor Unit Capacity (%): 100	
Cooling	
Indoor	
Dry bulb temperature:	80.6 °F
Relative Humidity:	47 %
Wet bulb temperature:	66.2 °F
Outdoor	
Dry bulb temperature:	95.0 °F
Heating	
Indoor	
Dry bulb temperature:	68.0 °F
Outdoor	
Dry bulb temperature:	44.6 °F
Relative Humidity:	87 %
Wet bulb temperature:	42.8 °F

System design conditions are easily entered such as indoor and outdoor design conditions for both heating and cooling. Also, the customer and project name can be entered to identify the job on the outputs.

Group	Indoor Unit	Local remote controller	DOO	System	ERV	Lossnay	FURDOO
1	001 FUYP20MUJE	001 PAC-210AA					
	002 FUYP20MUJE						
	003 FUYP20MUJE						
7	004 FUYP20MUJE	004 PAC-VISCRB					
	005 FUYP20MUJE						
3	006 FUYP20MUJE	006 PAC-210AA					
	007 FUYP20MUJE						
4	008 FUYP20MUJE	008 PAC-VISCRB					
	009 FUYP20MUJE						
6	010 FUYP20MUJE	010 PAC-210AA					
	011 FUYP20MUJE						
7	012 FUYP20MUJE	012 PAC-210AA					
	013 FUYP20MUJE						

Similar to the equipment section, the controls and Lossnay ERVs can be set up by selecting the style and dragging and dropping them into the design. Interlocking component operation is done with the click of a mouse.



**MITSUBISHI
ELECTRIC**

No: _____
 Project: _____
 Date: 09/19/2008

No: _____
 Project name: _____
 Date: 09/19/2008
 From: MITSUBISHI ELECTRIC CORPORATION
 Comment: _____

Proposal

Qty	Model	Description	Price
1	PURY-P192TSHMU-A	R410A R2 Series Outdoor Unit	
1	PCFY-P15NOMU-E	Ceiling suspended type Indoor Unit	
2	PMFY-P15NOMU-E	Ceiling cassette(1way air flow) type Indoor Unit	
2	PFY-P16NEMU-E	Floor standing type Exposed Indoor Unit	
2	PKFY-P12NOMU-E	Wall mounted type Indoor Unit	
1	PEFY-P12NMSU-E	Ceiling concealed type Indoor Unit	
4	PLFY-P12NBMU-E	Ceiling cassette(4way air flow) type Indoor Unit	
4	PLFY-P12NCMU-E	Ceiling cassette(4way air flow) type Indoor Unit	
1	CMY-R100VBK	Twinning kit	
1	CMB-P108NU-GA	BCcontroller main	
1	CMB-P108NU-GB	BCcontroller sub	
1	AQ-150A	Central controller	
6	PAR-21MAA	MA remote controller	
2	PAC-YT51CRB	Simple MA controller	
1	LOH-F300RC3-E	Lossnay	
1	PAC-SC51KUA	Power supply unit	

The system is summarized in an Excel (.xls). Included are all the design parameters, equipment list, line sizes, indoor unit operating capacities, additional refrigerant based on the line lengths, control scheme with addressing and much, much more. The Excel-based output simplifies quoting a job and tracking equipment lists.

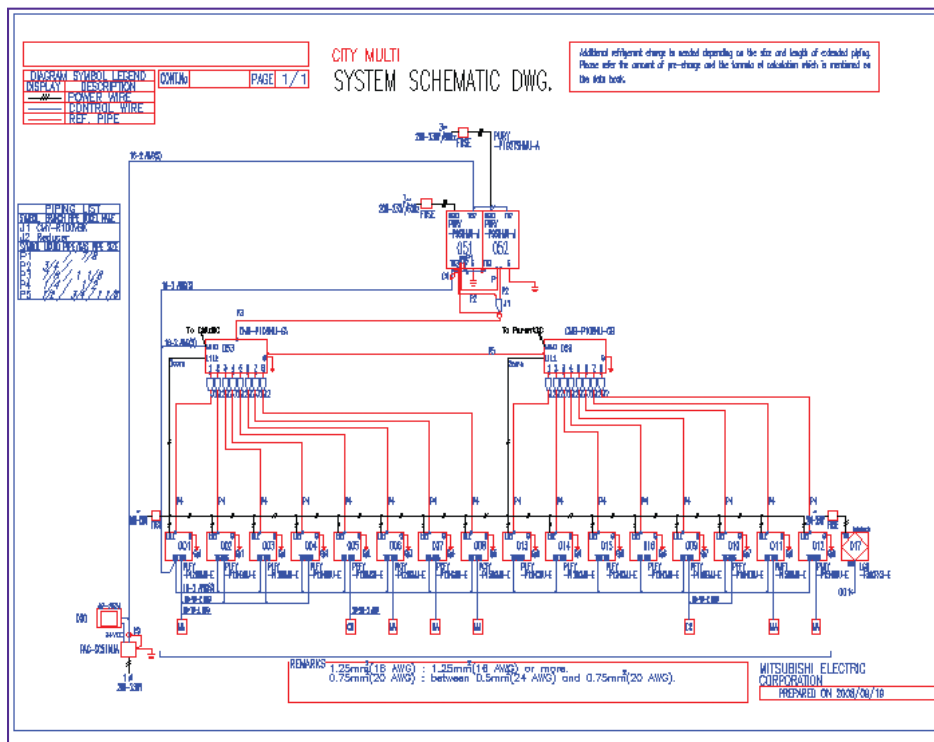

With the help of AutoCAD* or AutoCAD LT* installed on the computer, a schematic (.dwg format) is generated that includes all the requirements to make installation a breeze. Included in the drawing are line sizes, wiring diagram with indoor units grouped as designed, labels on indoor units, addressing and so much more.

The AutoCAD drawing is a valuable guideline for every installation.

*computers must have AutoCAD or AutoCAD LT installed to create .dwg drawings

Mitsubishi Electric Air Conditioning & Refrigeration Systems Works acquired ISO 9001 certification under Series 9000 of the international Standard Organization (ISO), based on a review of quality warranties for the production of refrigeration and air conditioning equipment.

ISO Authorization System

The ISO 9000 series is a plant authorization system relating to quality warranties as stipulated by the ISO. ISO 9001 certifies quality warranties based on the "design, development, production, installation and auxiliary services" for products built at an authorized plant.

Mitsubishi Electric Air Conditioning & Refrigeration Systems Works acquired environmental management system standard ISO 14001 certification.

The ISO 14000 series is a set of standards applying to environmental protection set by the International Standard Organization (ISO).



Certificate Number FM33568



Certificate Number EC97J1227



See complete warranty for terms, conditions, and limitations. A copy is available from Mitsubishi Electric, 3400 Lawrenceville Suwanee Road, Suwanee, GA 30024



HVAC Advanced Products Division

Mitsubishi Electric & Electronics USA, Inc.

www.mehvac.com

© 2008 Mitsubishi Electric and Electronics USA, Inc.
CITY MULTI is a registered trademark of Mitsubishi Electric.
Mitsubishi Electric is a registered trademark of Mitsubishi Electric Corporation. The three-diamond logo is a registered logo of Mitsubishi Electric Corporation.

Windows and Excel are registered trademarks of the Microsoft Corporation. AutoCAD is a registered trademark of Autodesk. LON, LON WORKS®, and the Echelon logo are trademarks of Echelon Corporation, registered in the United States and other countries. BACnet® is a registered trademark of the American Society of Heating, Refrigerating, and Air-Conditioning Engineers (ASHRAE).

Specifications shown in this brochure are subject to change without notice.

CMTECH-09-08-30M PD