

Spiral tube forming machine ---ATM-1500

1. Price basis: **USD21,000.00** FOB Shanghai (CHINA)
2. Payment: 30% down payment by T/T in advance
the balance by T/T after you checked the machine in our factory
lead-time : within 15 days after receiving your payment.

Note:1.Above offer include all dies and spare part
2.Before deliver you could send one technician to our factory getting training, this training is free of charge.
3.Guarantee: within two years since the date of B/L

INTRODUCTION OF SPIRAL TUBE FORMING MACHINE

This machine line is for producing round air duct for various uses, such as for HVAC round ducts, oval ducts, chimney flue, etc.

I Advantages

- 1.1 Special mould for various tube diameters, very easy to change and adjust, no needs crane or too much manpower.
- 1.2 Large diameter range
- 1.3 High speed synch flying cutting system.
- 1.4 PLC computer control, convenient operation
- 1.5 Light and small, suitable for site work.

II Main technical data

- 2.1 Diameter of round tubes:85mm ~ 1500mm.
- 2.2 Max. Tube length: unlimited.
- 2.3 Thickness of strip: 0.35 ~ 1.2mm
- 2.4 Width of strip: 137mm ~ 140mm
- 2.5 Strip speed: 1~40m/min, adjustable
- 2.6 Suitable strip material: aluminum, stainless steel, galvanized steel, etc.
- 2.7 Dimension: 2350mm x 2200mm x 2580mm (can be loaded in one 20' container,
- 2.8 Weight: 2000kg
- 2.9 Power of main motor: 5.5kw,380Volt,50Hz



<http://www.tubemachine.com> EMAIL:pan@tubemachine.com
ADD: Building D, 299 Tangming Road, Litahui Songjiang District, Shanghai, China

Page 1 of 2

2.10 Power of cutting motor: 4kw

2.11 Pneumatic tank Pressure 0.5—0.7Mpa (compressor)

III Main configuration

3.1 Decoiler mechanical expanding type

3.2 Control system: JAPAN OMRON transducer, PLC control

3.3 Driving system: Spiral subulate gear type decelerator (low noise, large moment)

3.4 Hydraulic system: Electromagnetism valves are from Taiwan or imported from famous companies.

3.5 Material of forming rollers: GCr15 bearing steel, quenched, HRC58-62

IV Accessories accompanied with the machine

4.1 Unloading rack: one set, 2000mm long

4.2 Cutting blade: two pieces (including one piece on the machine)

4.3 Four press-adjusting rollers (changed to suit different thickness)

4.4 20m special steel strip for making strip mould

4.5 One set of special tools.

V Mounting way

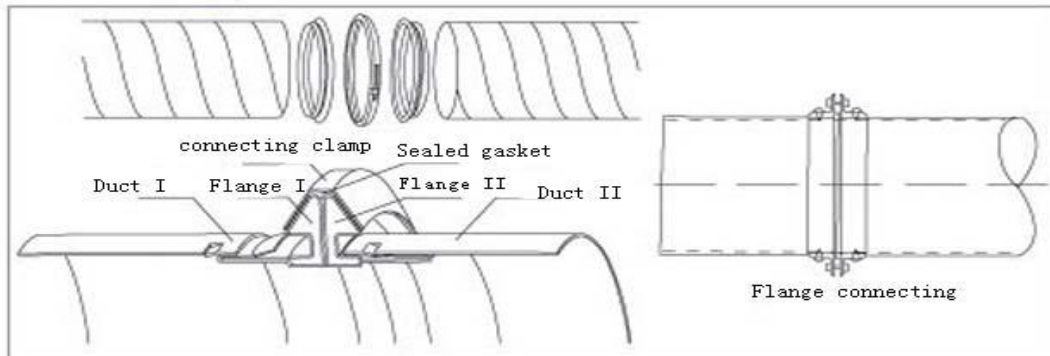

For Russian language:

Please call 0086---130 6171 5897, Mr. Xu

Or:0086---136 6991 6044, Mr. Yilahame