

ANALYSIS & TESTING OF TUBE SYSTEM FOR ROOF-LOAD TRANSFER TO JOISTS

Summary

Chicago Clamp Company's Tube Frame, for the transferring of roof loads to joists, consists of steel components: End Clamps, framing members (tubes), T-brackets, and hardware. The End Clamps connect the primary tubes to the top chords of the joists. The T-brackets connect the secondary tubes to the primary tubes. The positions of the secondary tubes between joists can be adjusted by sliding the T-brackets.

Analysis of the End Clamp indicates that it can support an allowable static load (net load) of 750 lbs. The smallest maximum load, applied in static testing, was 3,610 lbs per clamp. The clamp's static fracture load was not reached. Analysis and testing included consideration of both shear and bending of the bolts that transfer load from the tubes to the clamps. The bolts are SAE J429 (Grade 5), tightened to a usual snug condition. Analysis and testing were based on the worst-case position of support. In that case, the center of the support is 5" from the near edge of the clamp's deep section (i.e., the shallow section spans 5").

Analysis of the T-bracket indicates an allowable static load of substantially more than 750 lbs. A static test load of 4,910 lbs per bracket was applied with no failure.

The tested framing system consisted of cold-formed HSS 4" x 2" x 1/8" tubes (4" vertical, weighing 4.75 pounds per foot and conforming to A500 Grade B [46 ksi minimum yield]). The maximum span tested was 10'. Analysis was based on the 2005 edition of the AISC Specification (13th edition of the Steel Construction Manual) and a minimum safety factor of 2.0, which exceeds the minimum required value of 1.67 for flexure. A static strength-based allowable of 1,572 lbs was calculated for a concentrated load applied at the middle of an 8' span, and 1,249 lbs for a 10' span. For spans of 8' or less, the allowable load is limited to 1,500 lbs. Tubes are considered in this analysis to be braced only at the ends. A maximum static test load of 3,400 lbs was applied at the center of a 10' span, without failure. Allowable loads are also limited so that the tube's calculated deflection does not exceed span/240. This deflection limit is often used as a serviceability criterion for roof framing, but permissible design deflection is to be determined by the responsible design professional.

Adjustments of maximum test loads were made to account for possible differences between minimum and actual values of yield stress and thickness. The actual maximum test load was multiplied by the ratio of the tube's minimum-specified yield stress to the yield stress based on a test coupon. This partially-adjusted test value was then multiplied by 0.93 to account for the possibility that the tested tube had nominal rather than minimum thickness. The ratio of the fully-adjusted test load to the tube's allowable load was found to exceed 2.0. Similar adjustments were made for the strength of the End Clamp. The ratio, of the adjusted test load to clamp or bracket allowable, also exceeded 2.0.

The Engineer of Record is responsible for the design adequacy of the joists or beams that support the tube system.

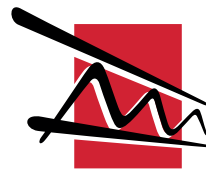

CHICAGO CLAMP CO

2350 South 27th Avenue ▪ Broadview, IL 60155 ▪ 708.343.8311
www.chicagoclampcompany.com

TUBE FRAMING CLAMP SYSTEM

THE NEW STANDARD FOR ROOF DECK SUPPORT AND FRAMING

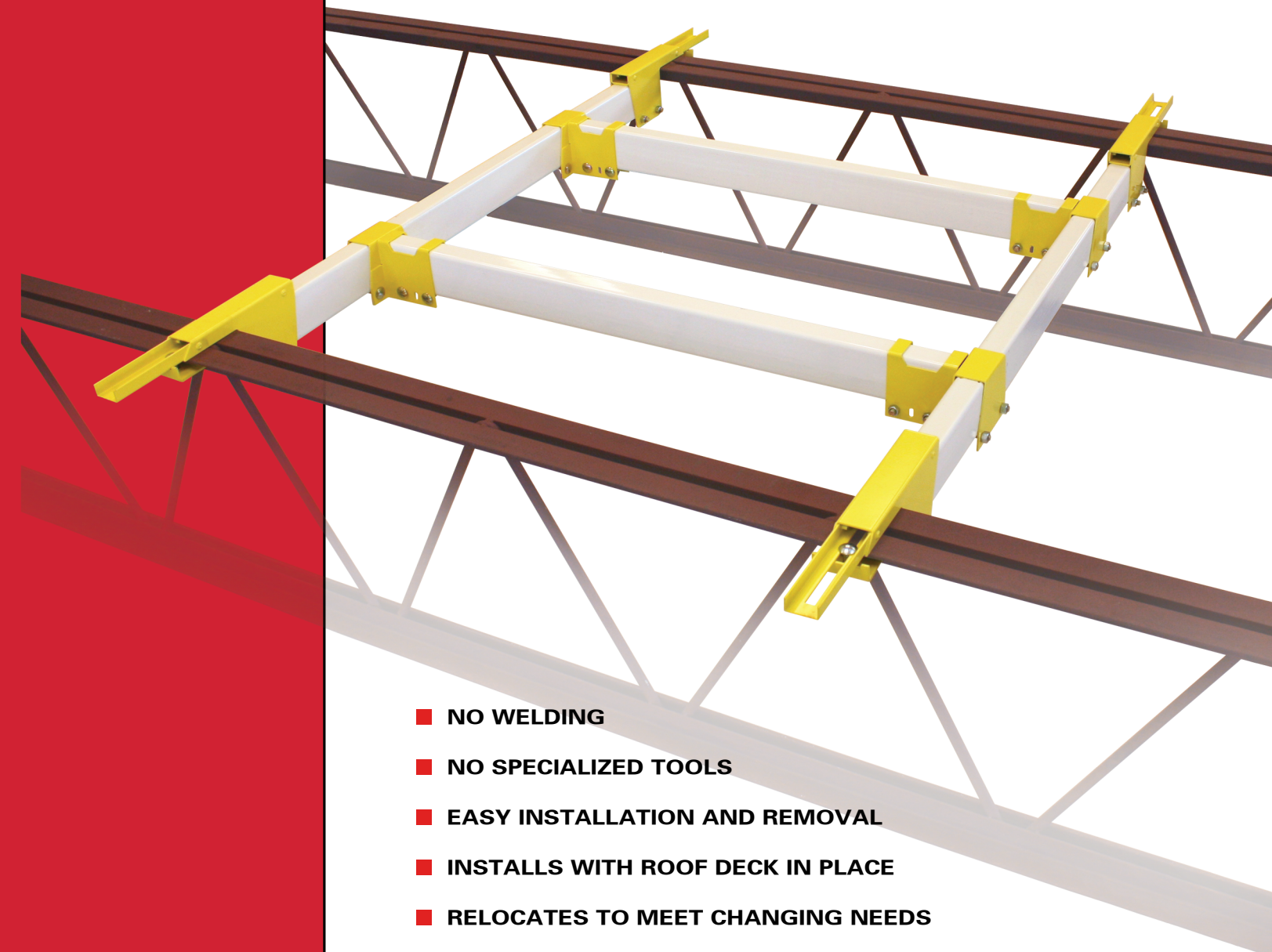

- NO WELDING
- NO SPECIALIZED TOOLS
- EASY INSTALLATION AND REMOVAL
- INSTALLS WITH ROOF DECK IN PLACE
- RELOCATES TO MEET CHANGING NEEDS
- REDUCES COST AND SHORTENS INSTALLATION SCHEDULE



Meticulously Engineered. Rigorously Tested.

CHICAGO CLAMP CO

www.chicagoclampcompany.com

Utilizing 30 years of engineering experience, Chicago Clamp Company was founded to create a structurally-sound, economical, and easy-to-install system for framing openings and distributing loads to joists. For decades, contractors have used traditional welded frame methods. Welding in the field comes with inherent costs, risks of fire, and the problem of fumes in operating facilities. To eliminate these costs and project risks, Chicago Clamp Company has developed three easy-to-use Chicago Clamp Systems®, which preserve the integrity of trusses and save installation time and money.

FROM FRAMING SIMPLE ROOF OPENINGS...

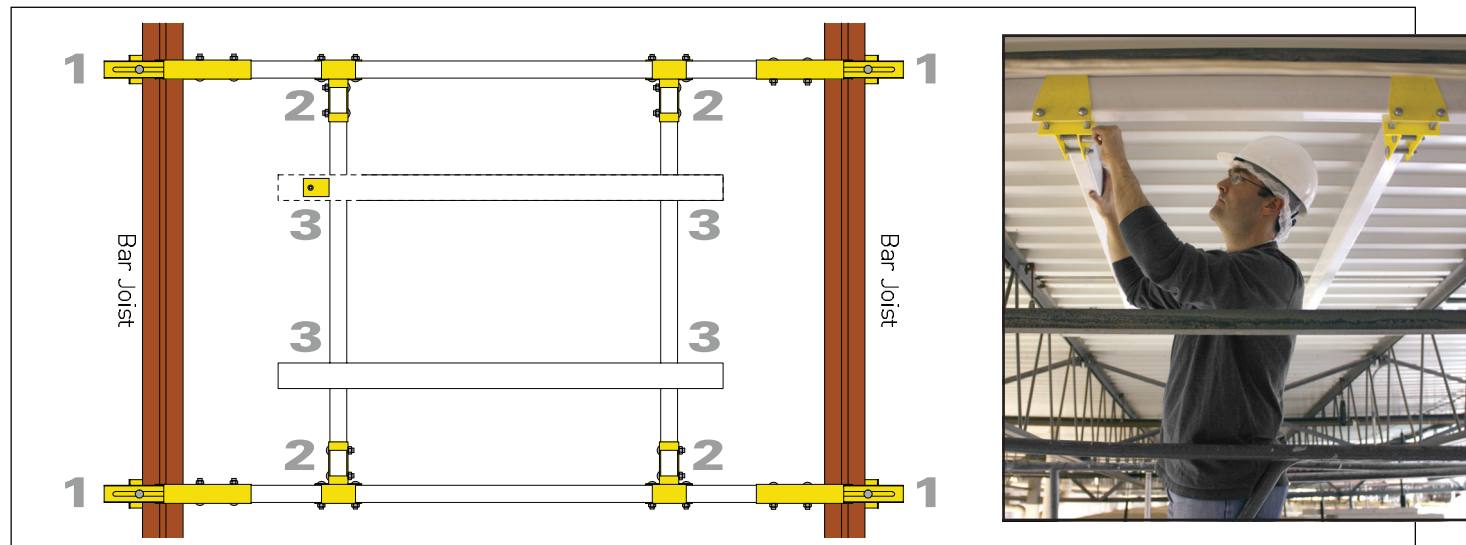

Frame roof openings for skylights, vents, exhaust fans, roof hatches, or other roof penetrations.

1 END CLAMPS

End Clamps slide over bar joists or wide-flange beams with a maximum top chord width of 8". They fit under the corrugations of the roof deck, occupying a 1 1/4" high by 2 1/2" wide space. Each End Clamp is rated for 750 lbs, giving the complete system a 3,000 lb distributed load capacity. Tubing is inserted and then secured with Grade 5 carriage bolts to each End Clamp.



2 T-BRACKETS

T-Brackets slide along the spanning tubes and are secured in place for easy installation and adjustment. Each T-Bracket is rated for 750 lbs and is secured to structural grade tubing with Grade 5 carriage bolts.

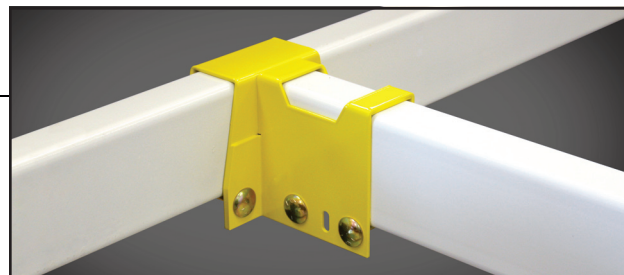

3 CROSS TUBE CLIPS

For additional framing support between panel points, 1 1/2" x 3" tubing can be inserted above Cross Tubes and secured with Cross Tube Clips. Self-tapping sheet metal screws are provided with clips.

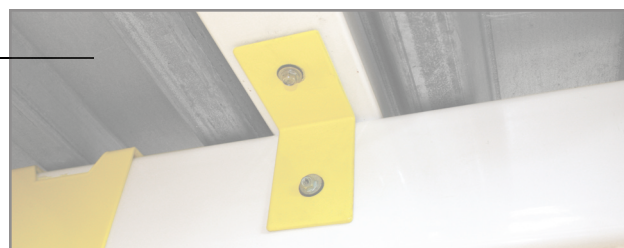

All Clamps shown in custom colors

TO MORE COMPLEX SUPPORT APPLICATIONS

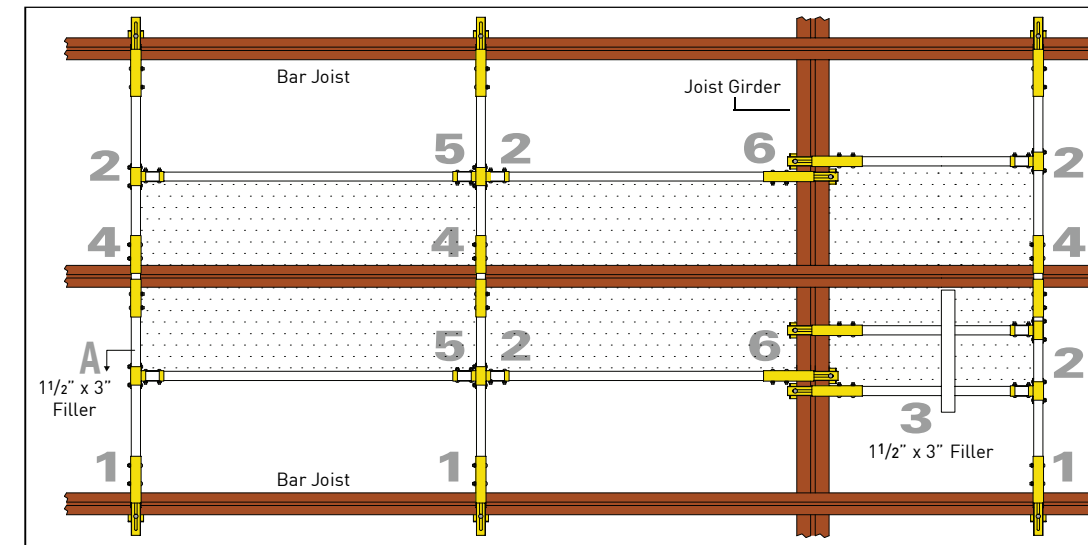

Support roof deck for installation of chillers, condensers, and other HVAC equipment.

4 INLINE END CLAMPS

For projects spanning multiple joist bays, InLine End Clamps allow for attachment of tubes on both sides of a joist. One part of the InLine Clamp slides over the joist, while the other secures it across the joist. Two self-locking bolts securely attach the clamps to the joist, preventing lateral movement along the joist. A perforated band adds extra security to system.

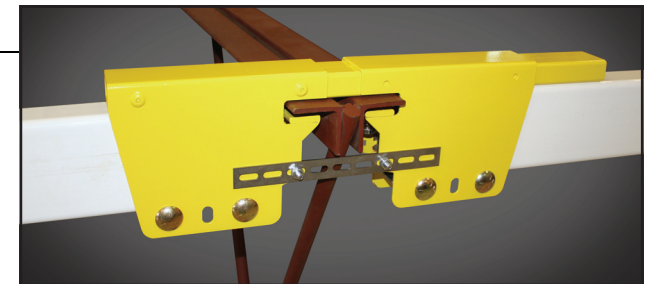

5 CROSS SUPPORT BRACKETS

The traditional T-Bracket can be combined with the Cross Support Bracket in order to support Cross Tubes across multiple Main Tubes.

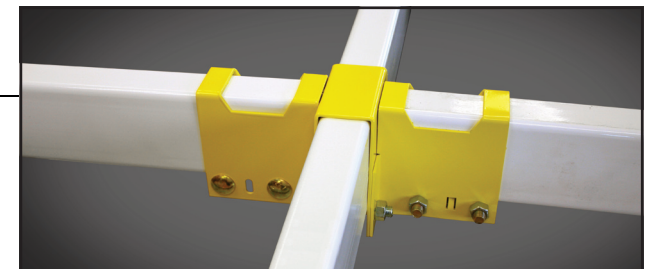

6 GIRDER CLAMPS

Girder Clamps are designed to secure tubing directly below and perpendicular to the roof deck flutes. Each Girder Clamp is designed to occupy the 2 1/2" gap between the girder and the roof deck. These clamps hold tubing even with the bottom of the roof deck, allowing installers to easily support units around girders.



DETAIL A MAIN TUBE CLIPS

For additional deck support along the main tube pocket, 1 1/2" x 3" tubing or wood filler can be inserted above the Main Tube and secured with the Main Tube Clip. Self-tapping sheet metal screws are provided with the clips.



All Clamps shown in custom colors

Visit
www.ChicagoClamp.com
to View Stencils,
Installation Guides, and
Demonstration Videos



To Place an Order Call
708.343.8311



01/12/09

Allowable Load (pounds) vs. Span ^{a-h}

Tube Size (inches)	Load Type	Span (feet)							
		3	4	5	6	7	8	9	10
HSS 4" x 2" x 1/8"	concentrated	1,500	1,500	1,500	1,500	1,500	1,500	1,318	1,067
	uniform	1,500	1,500	1,500	1,500	1,500	1,500	1,500	1,500
HSS 4" x 2" x 3/16"	concentrated	1,500	1,500	1,500	1,500	1,500	1,500	1,500	1,474
	uniform	1,500	1,500	1,500	1,500	1,500	1,500	1,500	1,500

a) Allowable concentrated load at middle of span. Allowable loads are net (weight of tube has been accounted for).
b) Multiple loads, that are symmetrically placed and whose total equals the tabulated value, may be used.
c) The reaction to each clamp bracket must be limited to a net value of 750 lbs.
d) Allowable loads have been limited to 1,500 lbs maximum.

e) Allowable loads are based on 46 ksi minimum yield steel (A500, Gr. B), the AISC specification and a safety factor of 2.0.
f) Loads in bold (1,318) are governed by applied-load deflection limit of Span / 240; [e.g., 0.50" for 10' span].
g) Tube's 4" dimension is vertical. Span is horizontal.
h) Tube weights: 4.75 lbs/ft for 1/8" wall, and 6.87 lbs/ft for 3/16" wall

NOTE: Modification or additional loading of any structure must be reviewed by a structural engineer. Each Chicago Clamp Systems® (CCS) application must be selected under direction of a structural engineer. CCS does not increase load capacity of any structure. Chicago Clamp Company (CCC) takes no responsibility for the load capacity of any building. Only use components provided by CCC.